

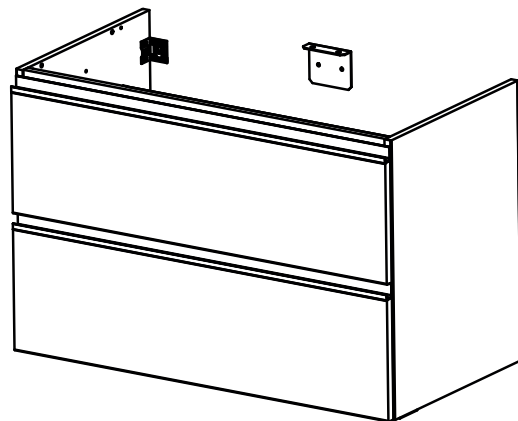

STUDIO

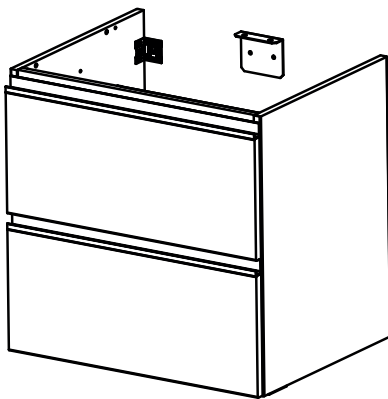
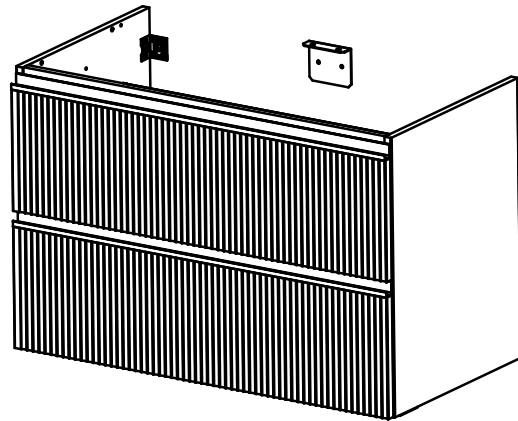
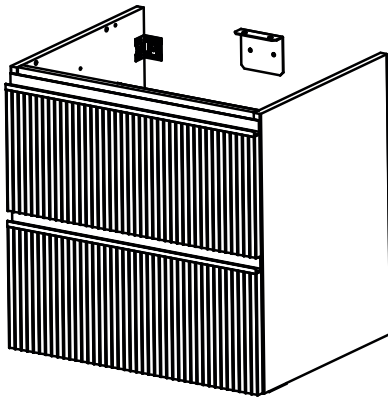

FR Notice de Montage -
Utilisation - Entretien

ES Instrucciones de Montaje,
Utilización y Mantenimiento

PT Instruções de Montagem,
Utilização e Manutenção

IT Istruzioni per il Montaggio,
l'Uso e la Manutenzione

EL Εγχειρίδιο συναρμολόγησης,
χρήσης και συντήρησης

PL Instrukcja Montażu,
Użytkowania i Konserwacji

UA Керівництво По Збірці
і Експлуатації

RO Manual asamblare,
utilizare și întreținere

EN Assembly - Use -
Maintenance Manual

FR: Nous vous remercions d'avoir acheté un produit SENSEA. Avant de commencer à utiliser votre nouveau produit, veuillez lire attentivement ces instructions afin d'optimiser ses performances et sa durée de vie. ce manuel dans un endroit sûr pour pouvoir vous y référer ultérieurement.

ES: Le agradecemos que haya comprado un producto S ENSEA Antes de utilizarlo, lea atentamente este manual para sacar el máximo partido a sus prestaciones y prolongar su vida útil. Guarde este manual en lugar seguro para poder volver a consultarlo más adelante.

PT: Agradecemos-lhe o facto de ter adquirido um produto SENSEA. Antes de começar a utilizar o seu novo produto, queira fazer o favor de ler atentamente estas instruções, no sentido de otimizar os desempenhos e a vida útil do mesmo. Conserve este manual em local seguro, para o poder consultar posteriormente.

IT: Vi ringraziamo per aver acquistato un prodotto SENSEA. Prima di utilizzare il vostro nuovo prodotto, leggete attentamente queste istruzioni allo scopo di ottimizzare le sue prestazioni e la sua durata. Conservate questo manuale in un luogo sicuro per future consultazioni.

EL: Σας ευχαριστούμε που επιλέξατε να αγοράσετε ένα προϊόν SENSEA. Προτού αρχίσετε να χρησιμοποιείτε το καινούργιο προϊόν σας, διαβάστε προσεκτικά αυτές τις οδηγίες, ώστε το προϊόν να έχει ιδανική απόδοση και μεγάλη διάρκεια ζωής. Φυλάξτε το εγχειρίδιο σε ασφαλές μέρος για να μπορείτε να ανατρέξετε σε αυτό στο μέλλον.

PL: Serdecznie dziękujemy za dokonanie zakupu produktu SENSEA. Przed rozpoczęciem korzystania z produktu należy dokładnie przeczytać niniejszą instrukcję, aby zapewnić optymalne parametry wydajnościowe i trwałość produktu. Instrukcja powinna być przechowywana w bezpiecznym miejscu do wykorzystania w przyszłości.

UA: Велике спасибі за придбання продукту SENSEA. Перш ніж почати використовувати новий продукт, будь ласка, уважно прочитайте наведені нижче інструкції, щоб оптимізувати його продуктивність і термін служби. Зберігайте цей посібник у надійному місці, щоб мати можливість регулярно звертатися до нього.

RO: Vă mulțumim pentru cumpărarea unui produs SENSEA. Înainte de a începe să utilizați noul dvs. produs, vă rugăm să citiți cu atenție aceste instrucțiuni, pentru a-i optimiza performanțele și durata de viață. Păstrați acest manual într-un loc sigur, pentru eventuale consultări ulterioare.

EN: Many thanks for having purchased a SENSEA product. Before starting to use your new product, please read the following instructions carefully to optimise its performance and life span. Keep this manual in a safe place so that you can refer to it regularly.



FR Mentions Légales & Consignes de Sécurité **ES** Instrucciones Legales y de Seguridad
PT Avisos Legais e instruções de Segurança **IT** Istruzioni Legali e di Sicurezza
EL Νομική ειδοποίηση και οδηγίες ασφαλείας **PL** Uwagi Prawne i Instrukcja Bezpieczeństwa
UA Керівництво з Техніки **RO** Manual privind siguranță **EN** Legal & Safety instructions



4 → 6

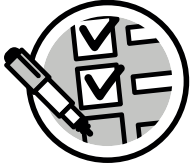

FR Préparation **ES** Preparación **PT** Preparação **IT** Preparazione **EL** Προετοιμασία
PL Przygotowanie **UA** Підготовка **RO** Pregătire **EN** Preparation



7 → 8



FR Montage **ES** Montaje **PT** Montagem **IT** Montaggio **EL** Συναρμολόγηση
PL Montaż **UA** Збірка **RO** Montaj **EN** Assembly



9 → 35



FR Entretien **ES** Mantenimiento **PT** Manutenção **IT** Manutenzione **EL** Συντήρηση
PL Konserwacja **UA** Технічне обслуговування **RO** Întreținere **EN** Maintenance



36



FR Montage des pieds **ES** Montaje de los pies **PT** Montagem dos pés
IT Montaggio dei piedi **EL** Συναρμολόγηση των ποδιών **PL** Montaż nóg
UA Монтаж меблевих ніжок **RO** Montarea picioarelor **EN** Assembly of the furniture legs



37 → 43

i



FR / IMPORTANT, À CONSERVER POUR CONSULTATION ULTÉRIEURE : À LIRE ATTENTIVEMENT

ES / IMPORTANTE, CONSERVAR PARA CONSULTAR POSTERIORMENTE: LEER ATENTAMENTE

PT / IMPORTANTE CONSERVAR PARA FUTURAS CONSULTAS: POR FAVOR, LEIA COM ATENÇÃO

IT / IMPORTANTE, DA CONSERVARE PER ULTERIORE CONSULTAZIONE: DA LEGGERE ATTENTAMENTE

EL / ΣΗΜΑΝΤΙΚΟ! ΚΡΑΤΗΣΤΕ ΤΟ ΓΙΑ ΜΕΛΛΟΝΤΙΚΗ ΑΝΑΦΟΡΑ. ΔΙΑΒΑΣΤΕ ΤΟ ΠΡΟΣΕΚΤΙΚΑ

PL / WAŻNE, PRZECZYTAĆ UWAŻNIE I ZACHOWAĆ NA PRZYSZŁOŚĆ

UA / ВАЖЛИВО, ЗБЕРІГАЙТЕ ДЛЯ МАЙБУТНЬОГО ДОВІДКУ: БУДЬ ЛАСКА, ПРОЧИТАЙТЕ УВАЖНО

RO / IMPORTANT, A SE PASTRA PENTRU CONSULTAREA ULTERIOARA: CITIȚI CU ATENȚIE

EN / IMPORTANT, TO BE RETAINED FOR FUTURE REFERENCE: PLEASE READ CAREFULLY

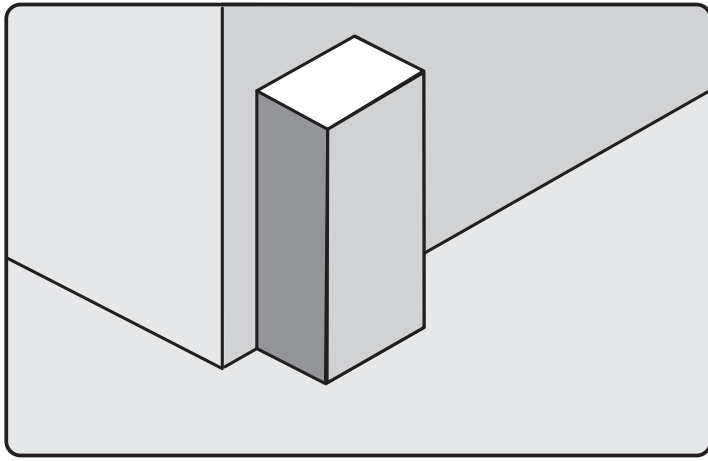

FR

AVERTISSEMENT:

Pour éviter tout risque de basculement, ce meuble/cet objet doit être solidement fixé au mur. Vérifier la pertinence et la solidité du mur afin de s'assurer que le mur puisse supporter la charge du meuble/de l'objet et résister aux forces générées au niveau des fixations. Un montage mal effectué peut provoquer la chute du meuble/de l'objet et des blessures graves sur les personnes. En cas de doute concernant l'installation, demandez conseil à un vendeur spécialisé ou contactez un professionnel.

* Utiliser des vis, rondelles et chevilles adaptées au type de matériau de votre mur. Celles-ci ne sont pas incluses. Pour obtenir des conseils sur les vis et ferrures adaptées à votre mur, adressez-vous à un vendeur spécialisé.

ES

ADVERTENCIA:

Para evitar cualquier riesgo de que se vuelque, el mueble u objeto debe anclarse firmemente a la pared. Compruebe la adecuación y la solidez de la pared para asegurarse de que puede soportar el peso del mueble u objeto y resistir las fuerzas que se produzcan en las fijaciones. Un montaje inadecuado puede causar la caída del mueble u objeto y que se produzcan daños corporales. En caso de duda en relación a la instalación, pregunte a un vendedor especializado o recurra a un profesional.

* Utilice tornillos, arandelas y tacos adecuados para el material de la pared. El producto no incluye la tornillería ni los tacos de sujeción. Para saber cuáles son los elementos de fijación más adecuados para su pared, pregunte a un vendedor especializado.

IT

ATTENZIONE:

Per evitare un eventuale rischio di ribaltamento, il mobile/l'oggetto deve essere saldamente fissato alla parete. Verificare l'adeguatezza e la solidità della parete per essere sicuri che la stessa possa sopportare il carico del mobile/dell'oggetto e resistere alle forze generate a livello di fissaggi. Un montaggio non effettuato correttamente può provocare la caduta del mobile/dell'oggetto e lesioni gravi alle persone. In caso di dubbio circa l'installazione, rivolgetevi a un venditore specializzato o contattate un professionista.

* Utilizzare viti, rondelle e pernotti (non inclusi) adeguati al tipo di materiale della vostra parete. (non inclusi) Per informazioni su viti e ferramenta adatti alla vostra parete, rivolgetevi a un venditore specializzato.

PT

AVISO:

Para evitar qualquer risco de basculamento, este móvel/objeto deve ser fixo à parede de forma segura. Verifique a adequabilidade e solidez da parede para se certificar de que pode suportar a carga do móvel/objeto e resistir às forças aplicadas ao nível das fixações. Uma montagem mal feita pode originar a queda do móvel/objeto e provocar danos pessoais graves. Em caso de dúvida em relação à instalação, peça aconselhamento a um vendedor especializado ou contacte um profissional.

* Utilize parafusos, anilhas e buchas adaptadas ao tipo de material da sua parede. Estes elementos de fixação não estão incluídos. Para obter aconselhamento sobre os parafusos e ferragens adaptados à sua parede, consulte um vendedor especializado.

EL

ΠΡΟΕΙΔΟΠΟΙΗΣΗ:

Για την αποφυγή οποιουδήποτε κινδύνου ανατροπής, το έπιπλο/ αντικείμενο πρέπει να στερεώνεται σταθερά στον τοίχο. Βεβαιωθείτε για την καταλληλότητα και σταθερότητα του τοίχου, προκειμένου να διασφαλίσετε ότι μπορεί να υποστηρίξει το φορτίο του επίπλου/ αντικειμένου και να αντέξει στις δυνάμεις που δημιουργούνται στα σημεία των στηριγμάτων. Η κακή τοποθέτηση μπορεί να οδηγήσει σε πτώση του επίπλου/ αντικειμένου και σοβαρούς τραυματισμούς ατόμων. Σε περίπτωση αμφιβολίας σχετικά με την εγκατάσταση, ζητήστε συμβουλές από έναν εξειδικευμένο πωλητή ή καλέστε έναν επαγγελματία.

* Χρησιμοποιήστε κατάλληλες βίδες, ροδέλες και ούπα ανάλογα με το υλικό της τοιχοποιίας σας. Τα υλικά αυτά δεν περιλαμβάνονται. Για συμβουλές σχετικά με τις βίδες και τα μεταλλικά στηρίγματα που ενδείκνυται για τον τοίχο σας, απευθυνθείτε σε έναν εξειδικευμένο πωλητή.

OSTRZEŻENIE:

Aby uniknąć ryzyka przewrócenia, mebel/produkt musi zostać solidnie przymocowany do ściany. Sprawdź, czy ściana jest odpowiednia i solidna, aby mieć pewność, że jest w stanie utrzymać obciążenie mebla/produktu i siły na poziomie mocowań. Nieprawidłowo wykonany montaż może spowodować upadek mebla/produktu prowadzący do poważnych obrażeń ciała. W razie wątpliwości dotyczących montażu, należy zasięgnąć porady u kompetentnego sprzedawcy lub skontaktować się z fachowcem.

* Użyj śrub, podkładek i kołków odpowiednich do rodzaju ściany. Elementy te nie są dołączone do zestawu. Aby zasięgnąć porady na temat odpowiednich śrub i okuć należy skontaktować się z kompetentnym sprzedawcą.

AVERTIZARE:

Pentru a evita orice risc de basculare, această mobilă/acest obiect trebuie fixat/ă bine de perete cu ajutorul dispozitivului de fixare furnizat. Verificați rezistența și soliditatea peretelui, pentru a vă asigura că acesta poate suporta greutatea mobilei/obiectului și poate rezista forțelor generate la nivelul dispozitivelor de fixare. Montarea efectuată greșit poate determina căderea mobilei/obiectului și vătămarea gravă a persoanelor. În caz de dubii privind instalarea, cereți sfatul unui comerciant specializat sau contactați un profesionist.

* Utilizați șuruburi, șaibe și știfturi adaptate tipului de material a peretelui. Acestea nu sunt incluse. Pentru a obține recomandări privind șuruburile și felurile adaptate peretelui dvs., adresați-vă unui comerciant specializat.

ПОПЕРЕДЖЕННЯ:

Щоб уникнути будь-якого ризику перекидання, цей предмет меблів/об'єкт має бути надійно прикріплений до стіни. Перевірте придатність і міцність стіни, щоб переконатися, що стіна може витримати навантаження від меблів/об'єкта і витримувати зусилля, що діють на елементи кріплення. Неправильний монтаж може призвести до пошкодження меблів/предмету впасти та завдати серйозних травм людям. У разі сумнівів щодо встановлення зверніться за порадою до спеціалізованого продавця або зверніться до професіонала.









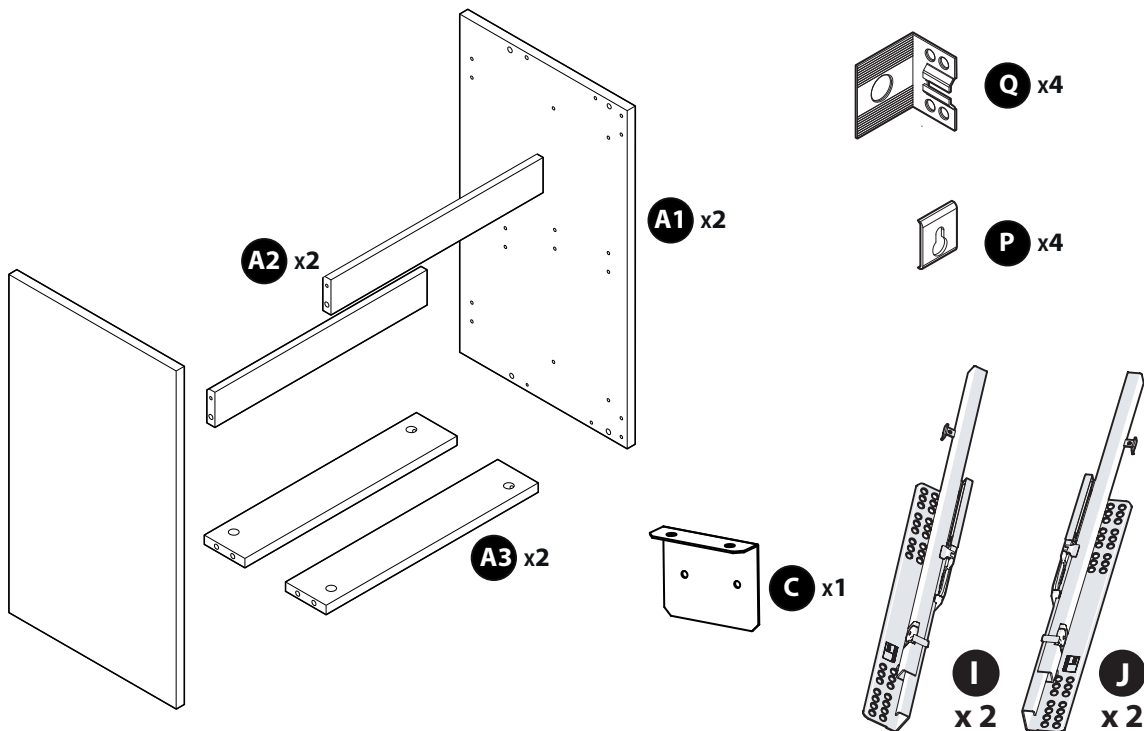

* Використовуйте шурупи, шайби та дюбелі, які відповідають типу матеріалу, з якого використовується ваша стіна. Вони не включені. Щоб дізнатися, які шурупи та кріплення підходять для вашої стіни, зверніться до досвідченого продавця.

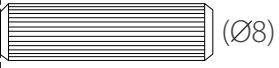
WARNING:

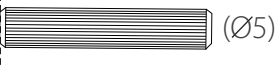
To avoid any risk of toppling, this furniture item/object must be securely attached to the wall. Check the suitability and the strength of the wall to ensure that the wall can bear the load of the furniture/object and withstand the forces put on the securing elements. Improper installation can result in the furniture/object falling and cause serious injuries to people. In case of a doubt regarding the installation, ask for advice from a specialised sales assistant or contact a professional.

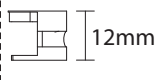
* Use screws, washers and plugs suited to the type of material of your wall. These are not included. To obtain advice on the screws and fittings suited to your wall, ask a specialised sales assistant.

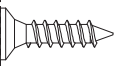

-   **Z** x8
-   (Ø8) **Y** x4
-   (Ø5) **X** x4
-   12mm **V** x8
-   **T** x4
-   **S** x16

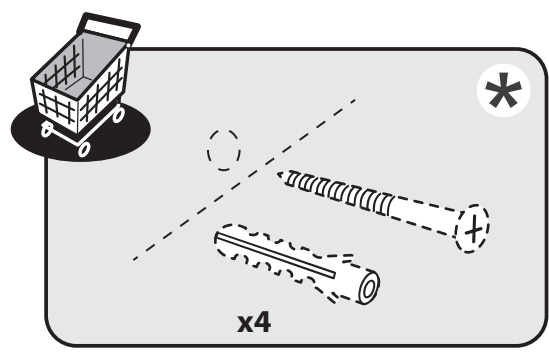
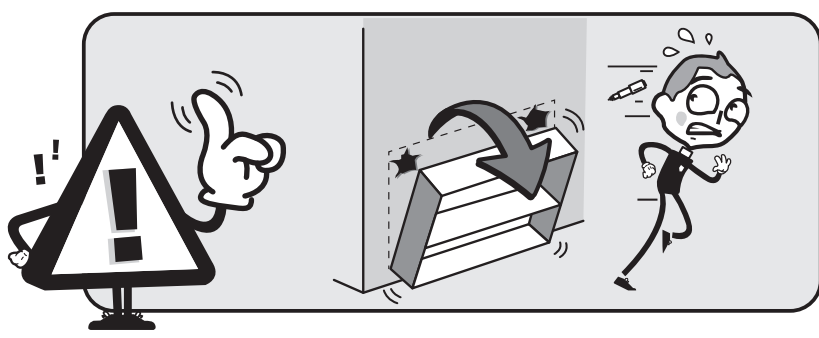
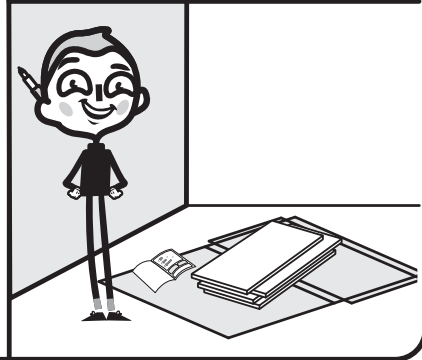
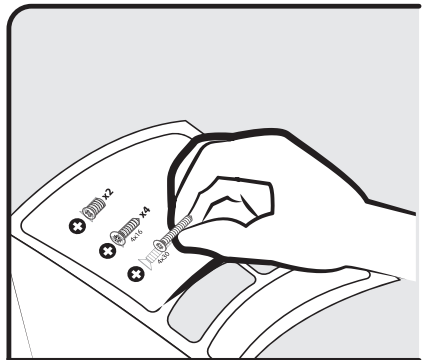

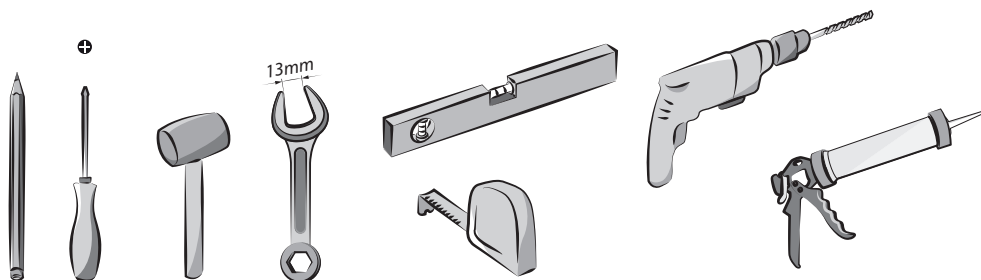
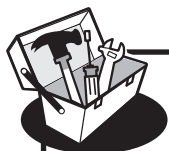
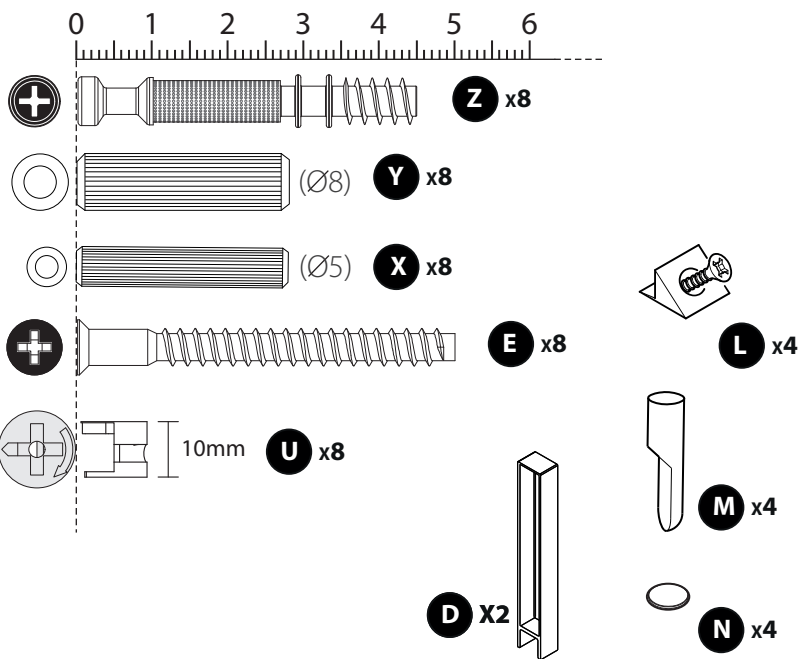
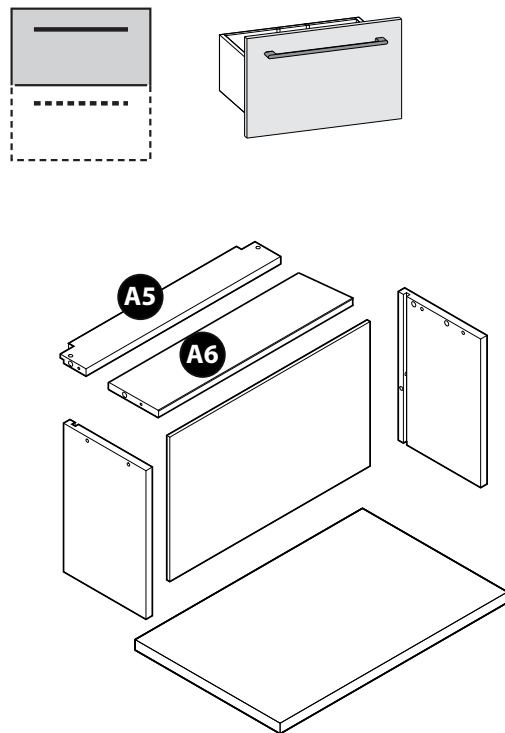
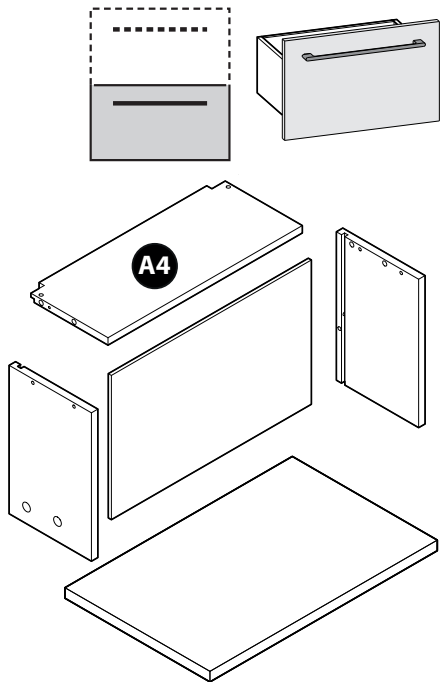

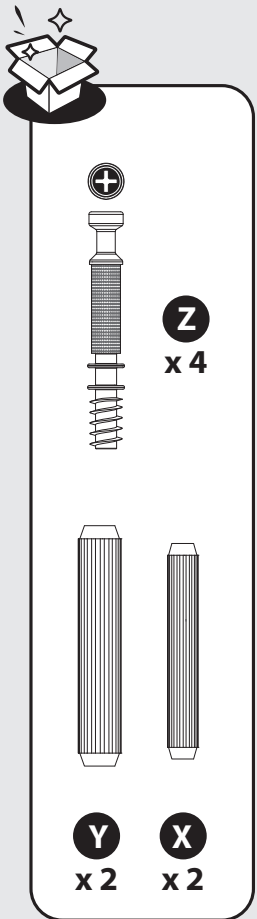
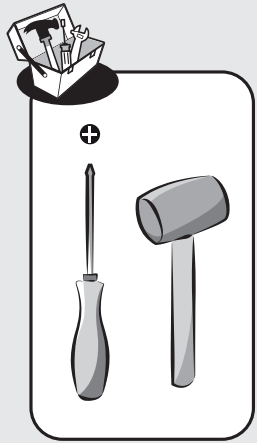
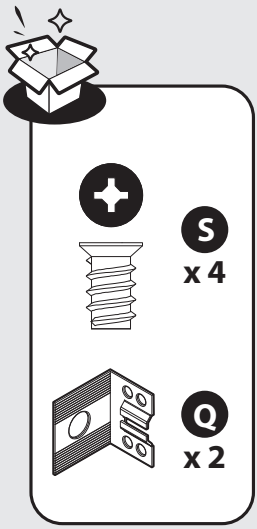

1

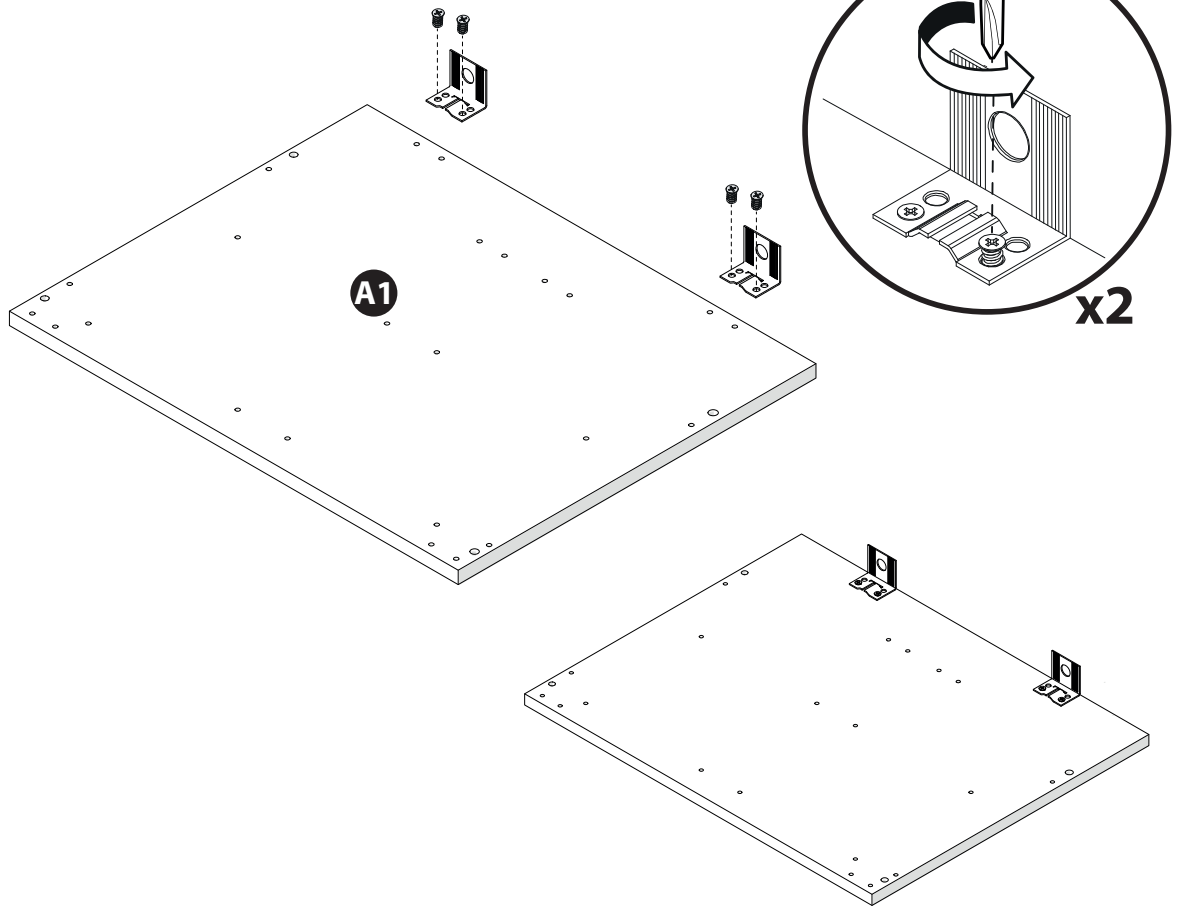

2

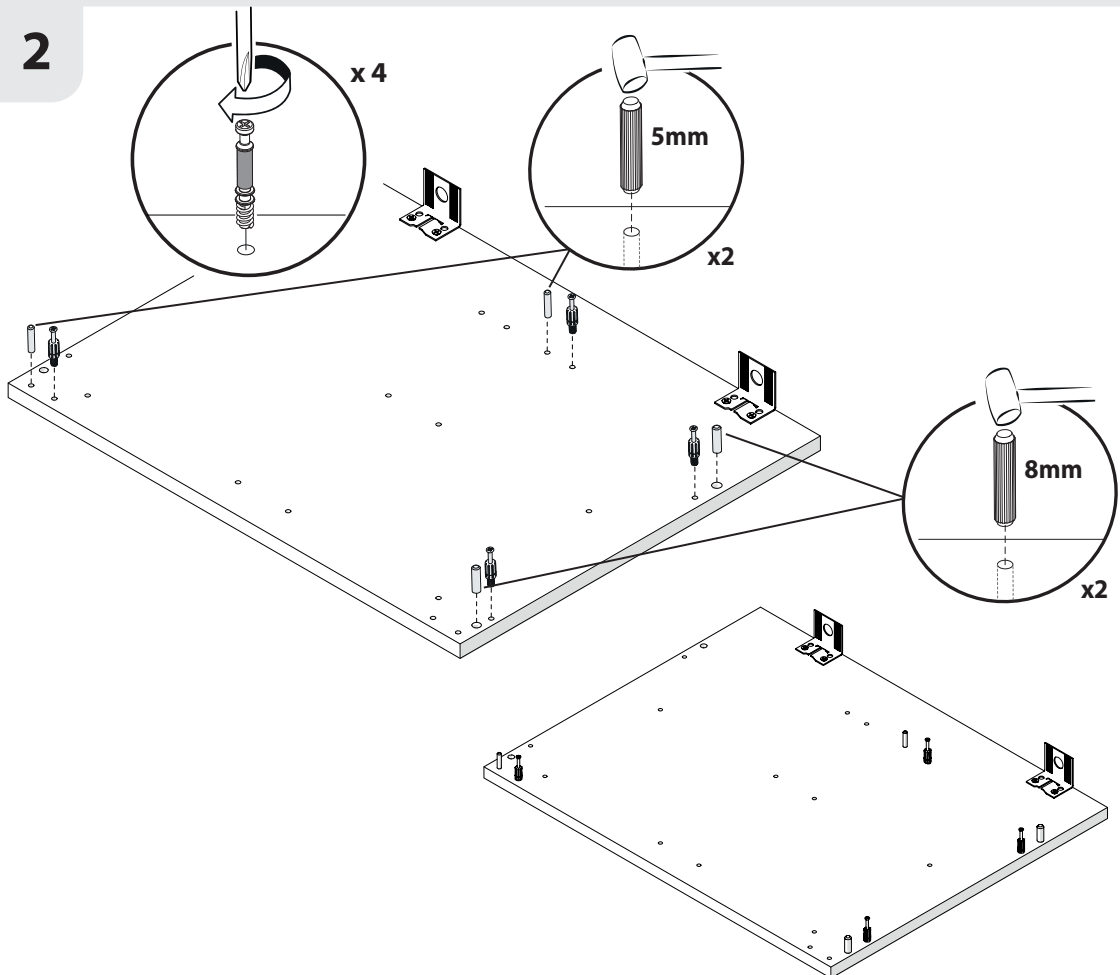



+



+

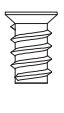

T

x 2

S

x 4

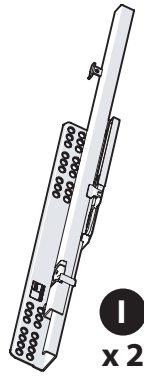

I

x 2



+

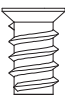

S

x 4

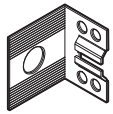

Q

x 2

3

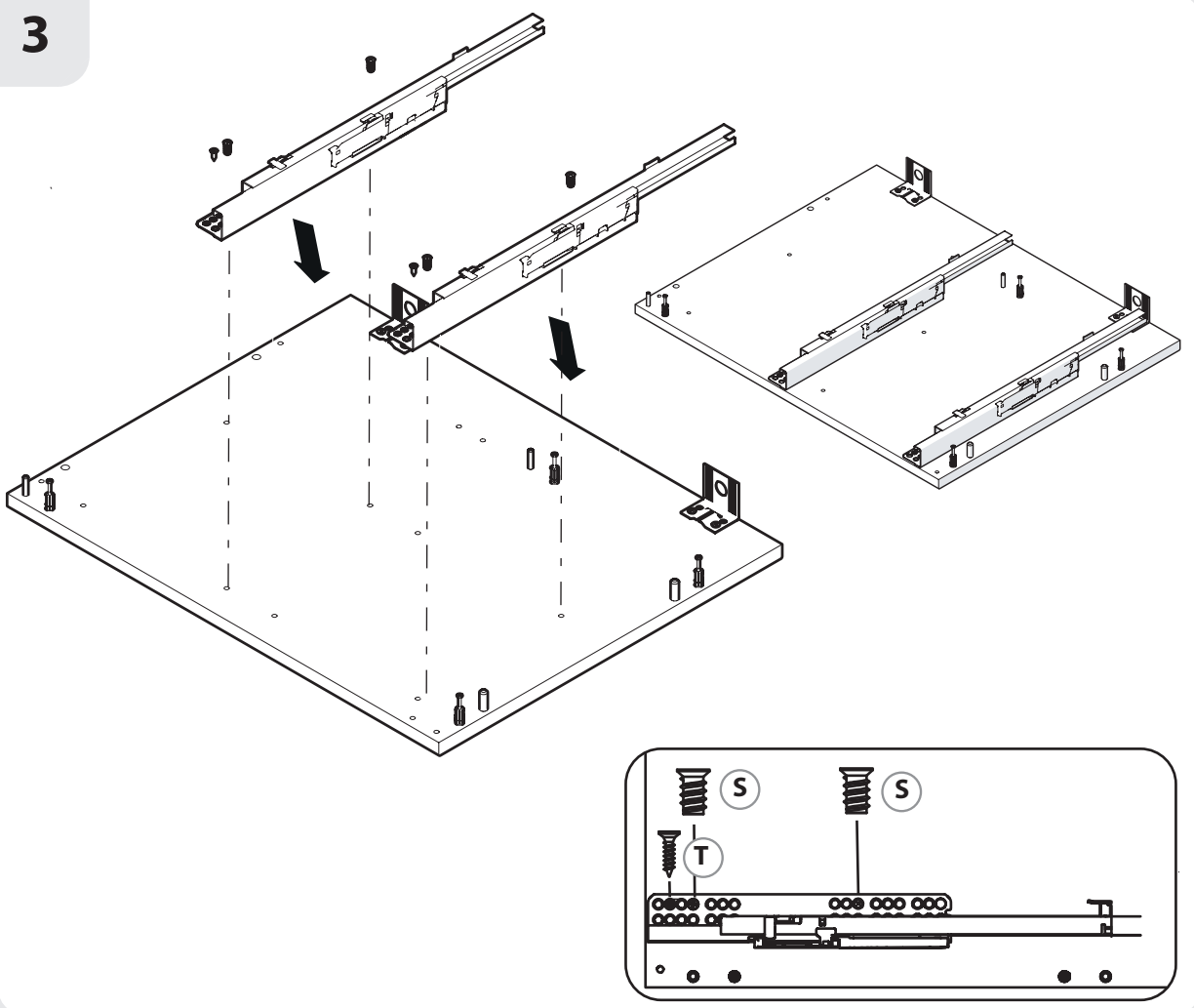

4

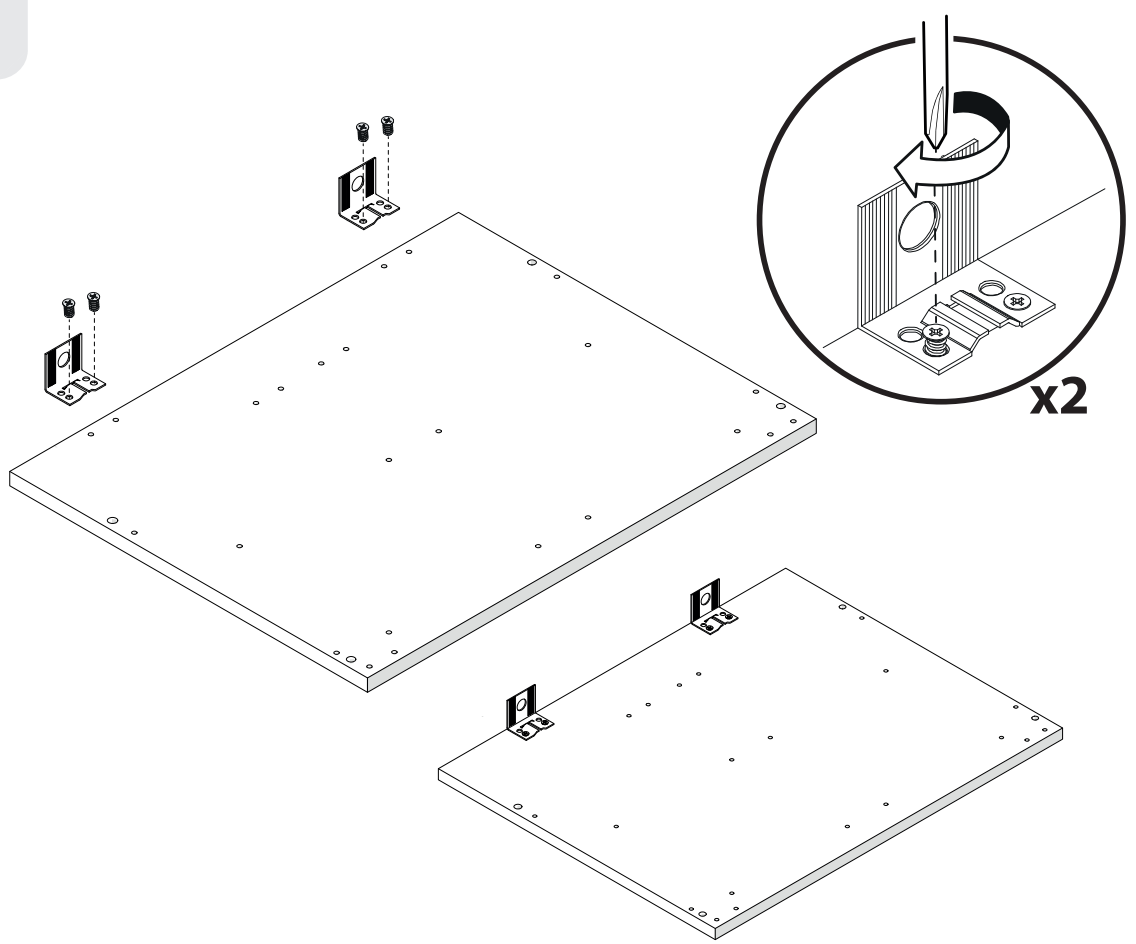

5

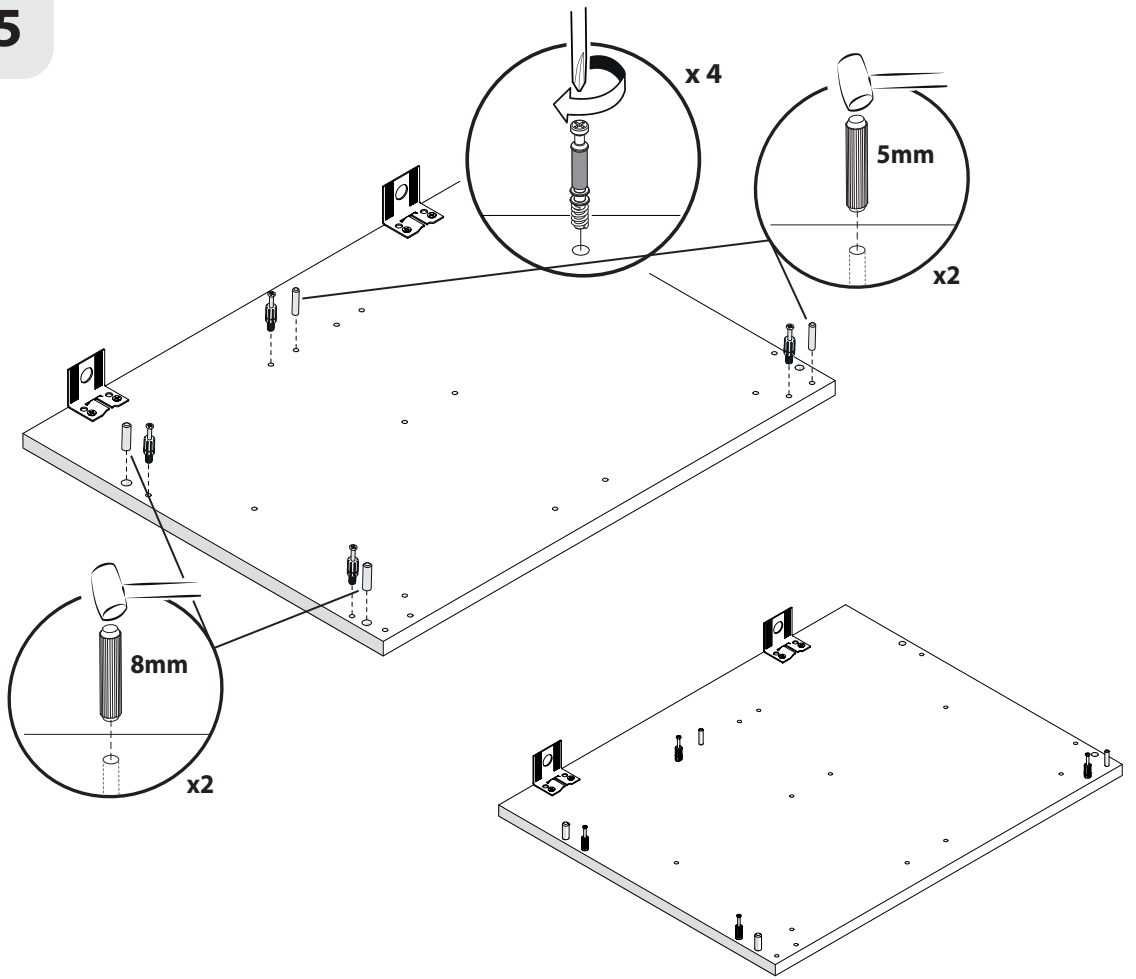
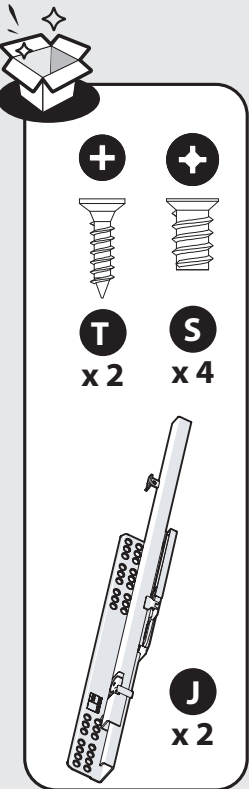
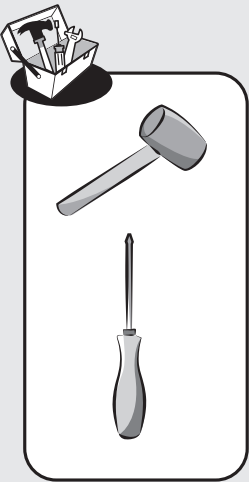
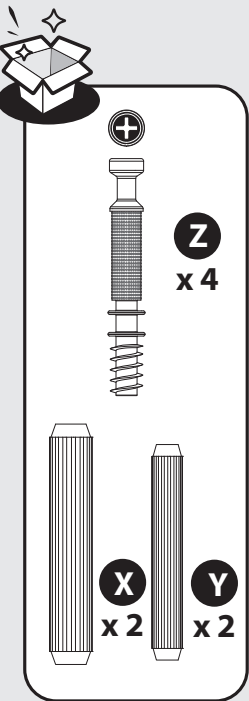

6

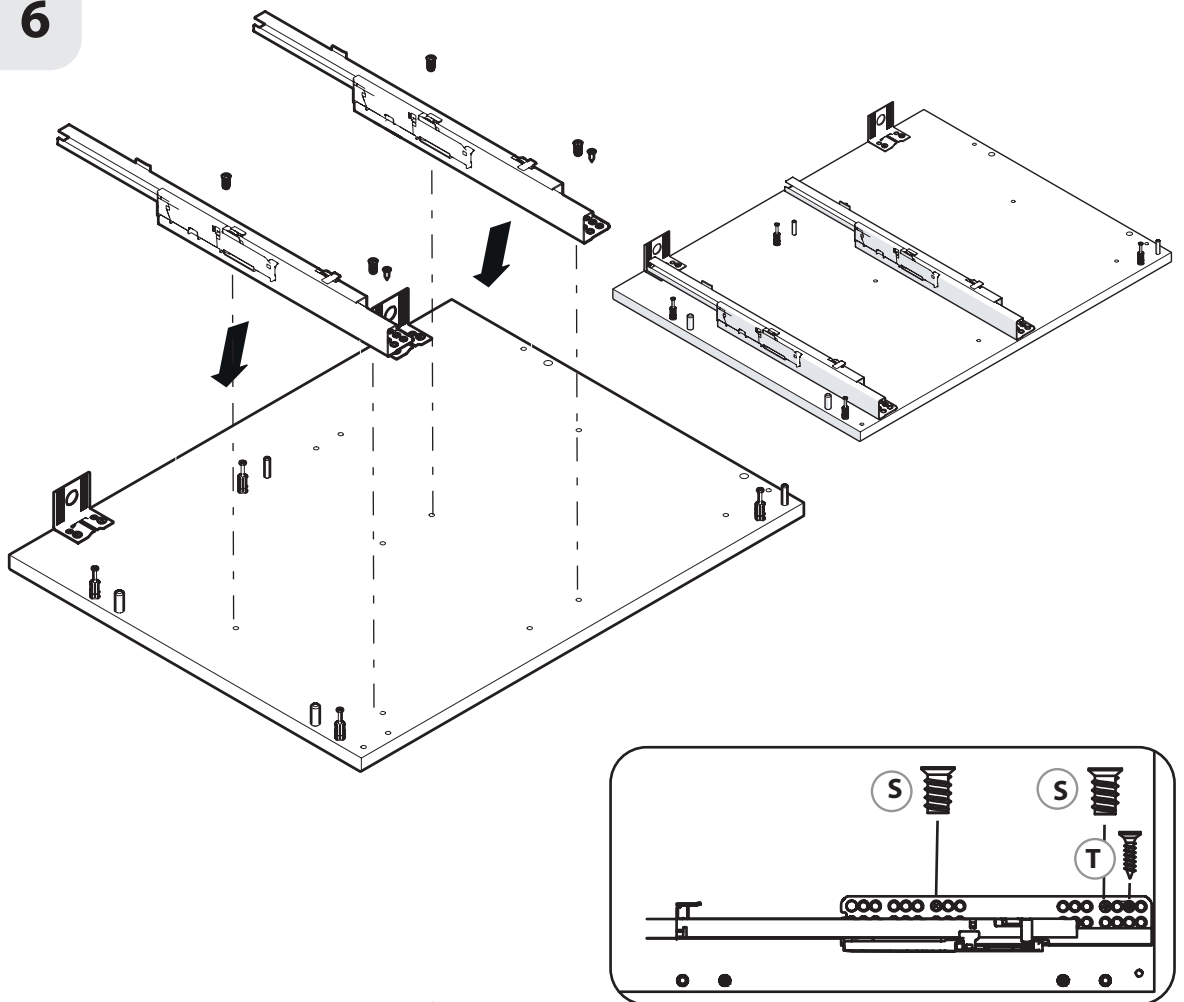

7

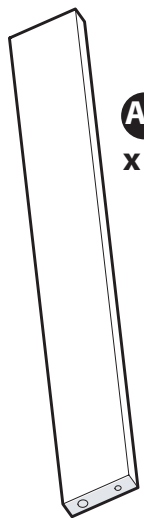

A2
x 2

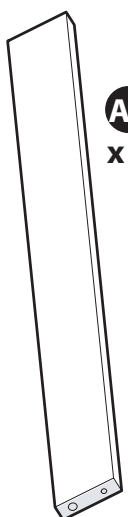

A3
x 2

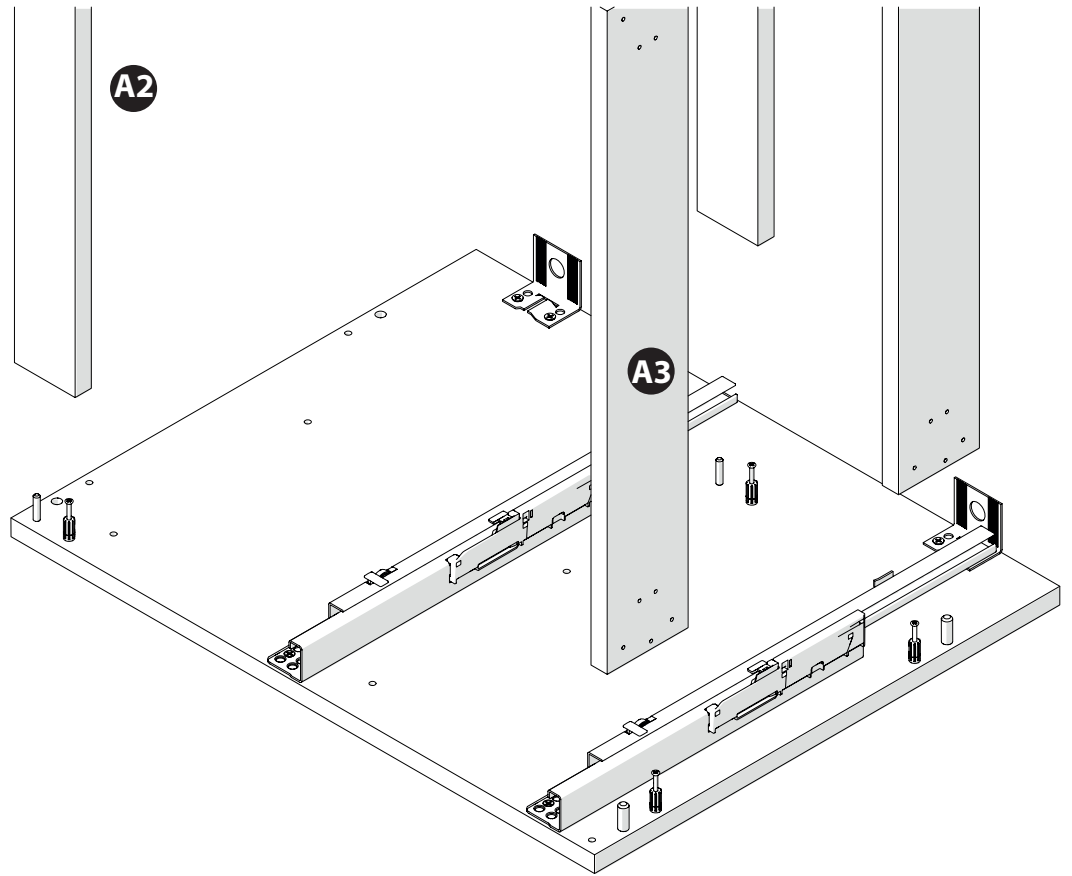

8

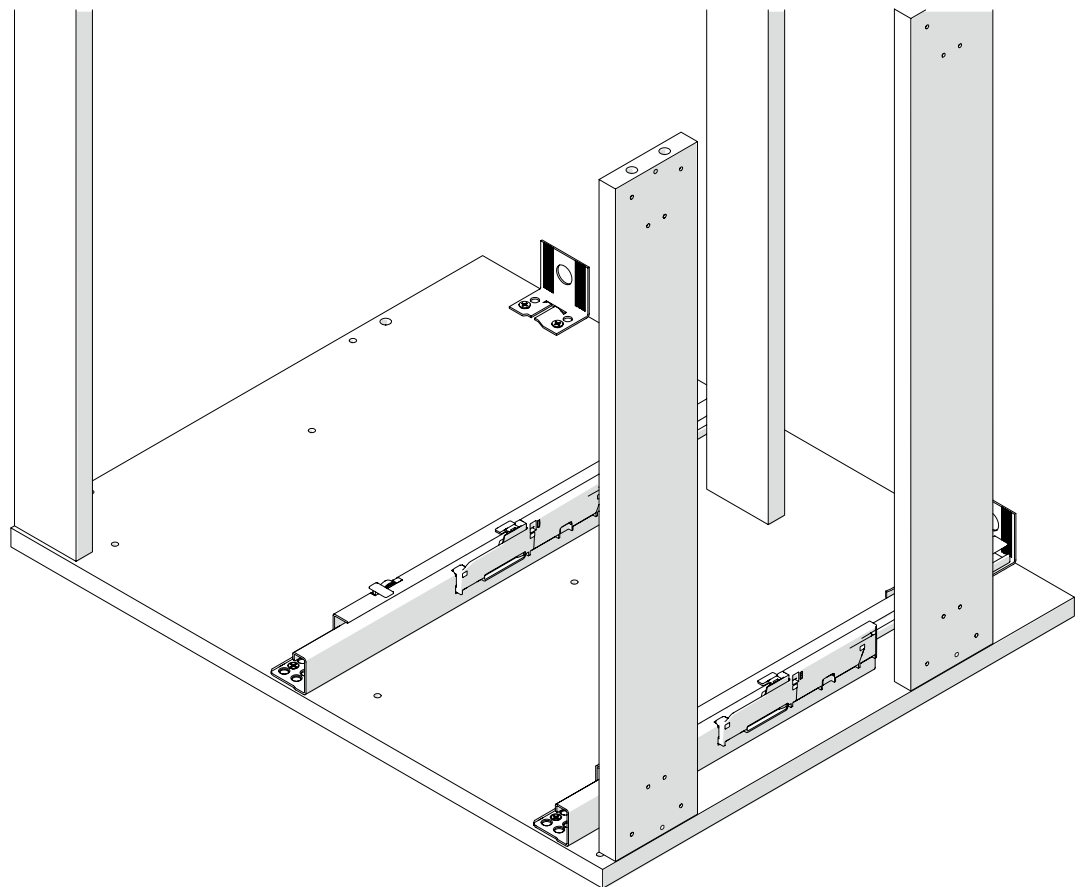

9

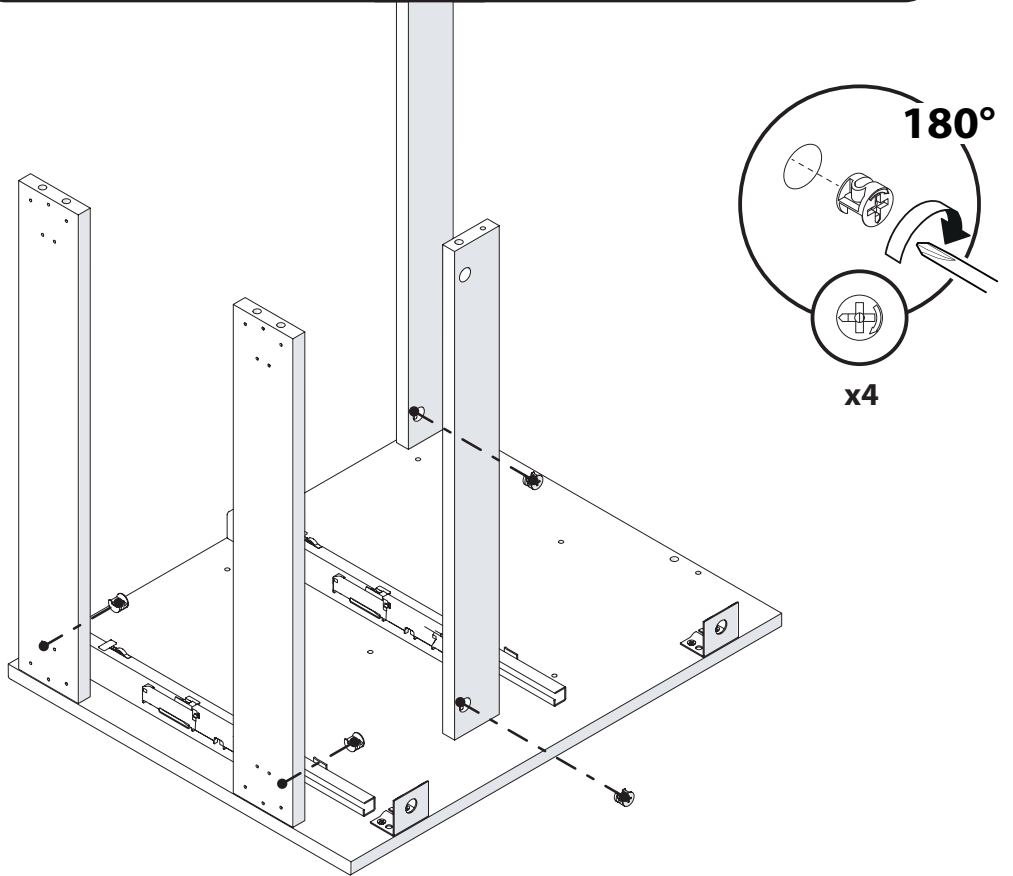
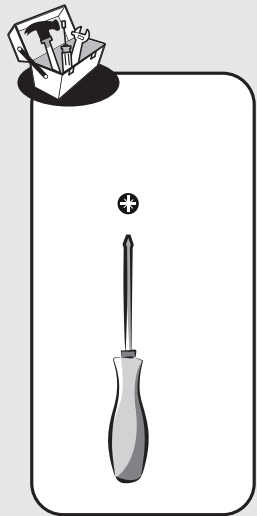
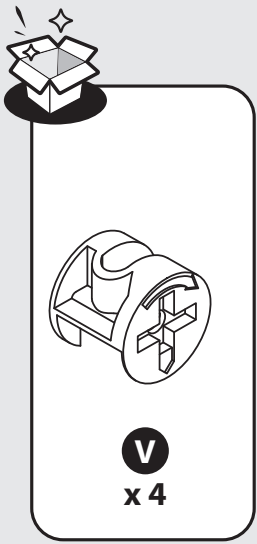
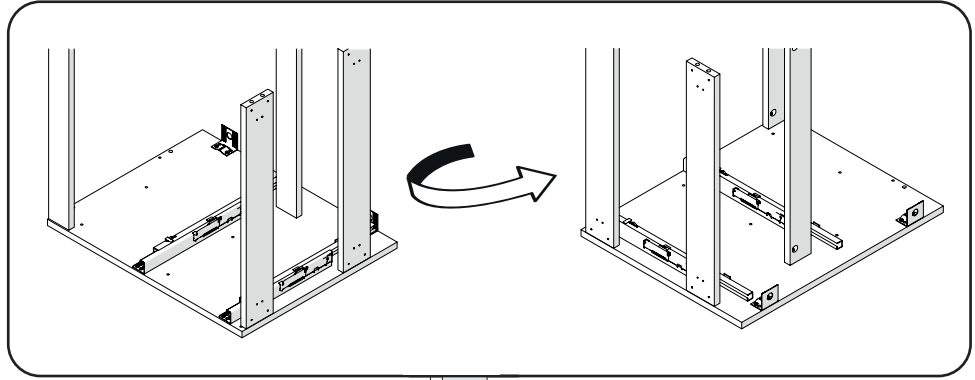

10

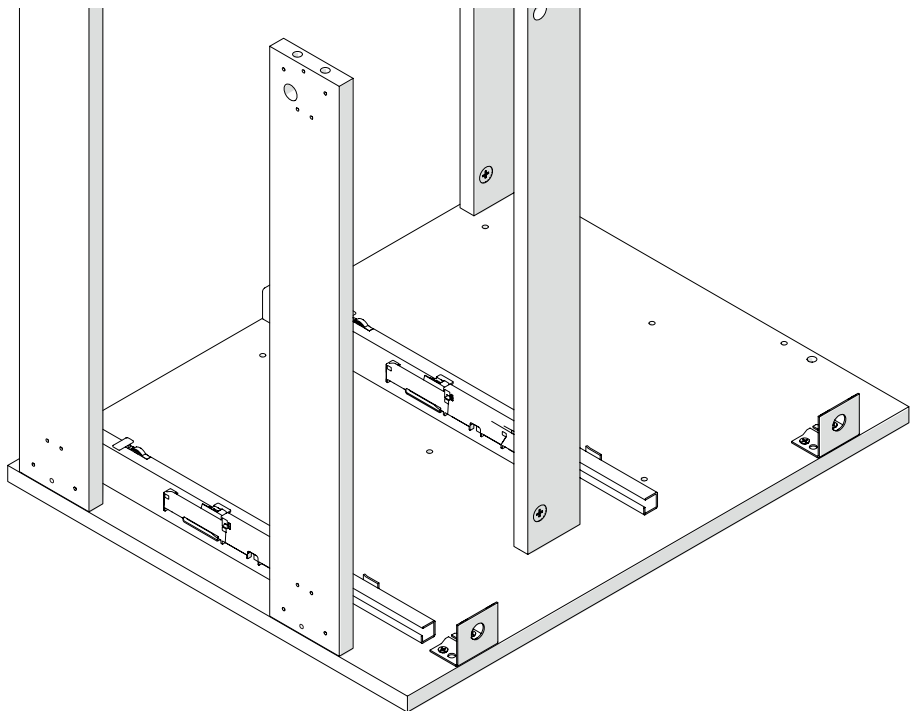

11

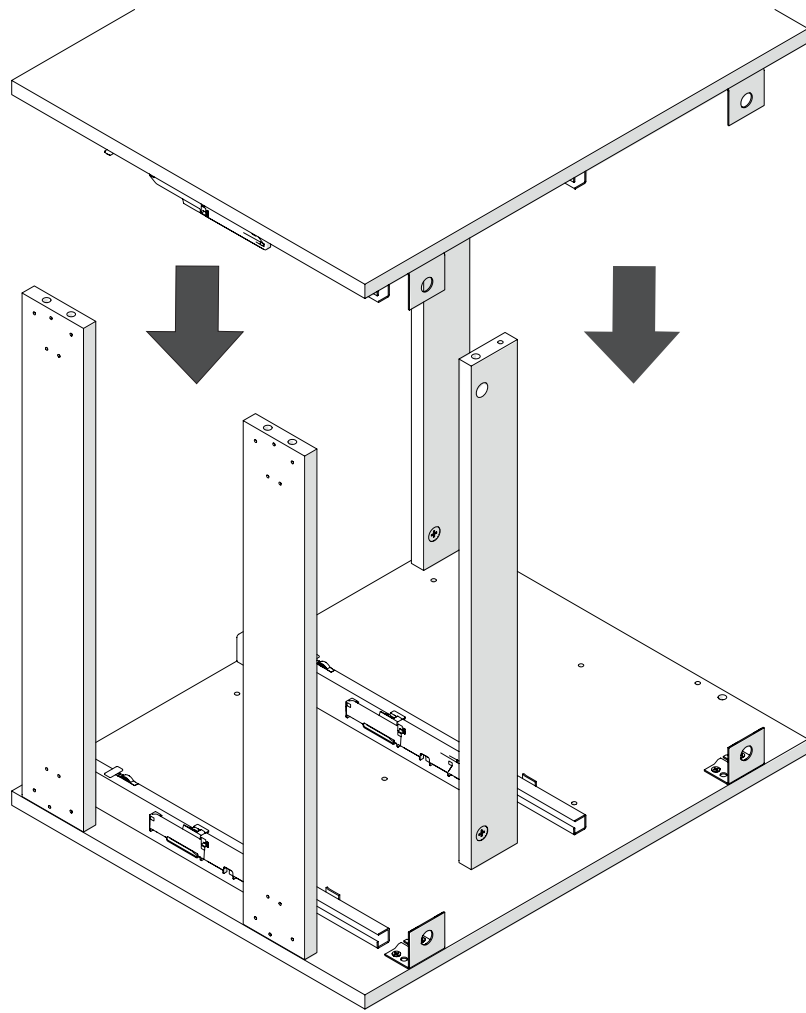

12

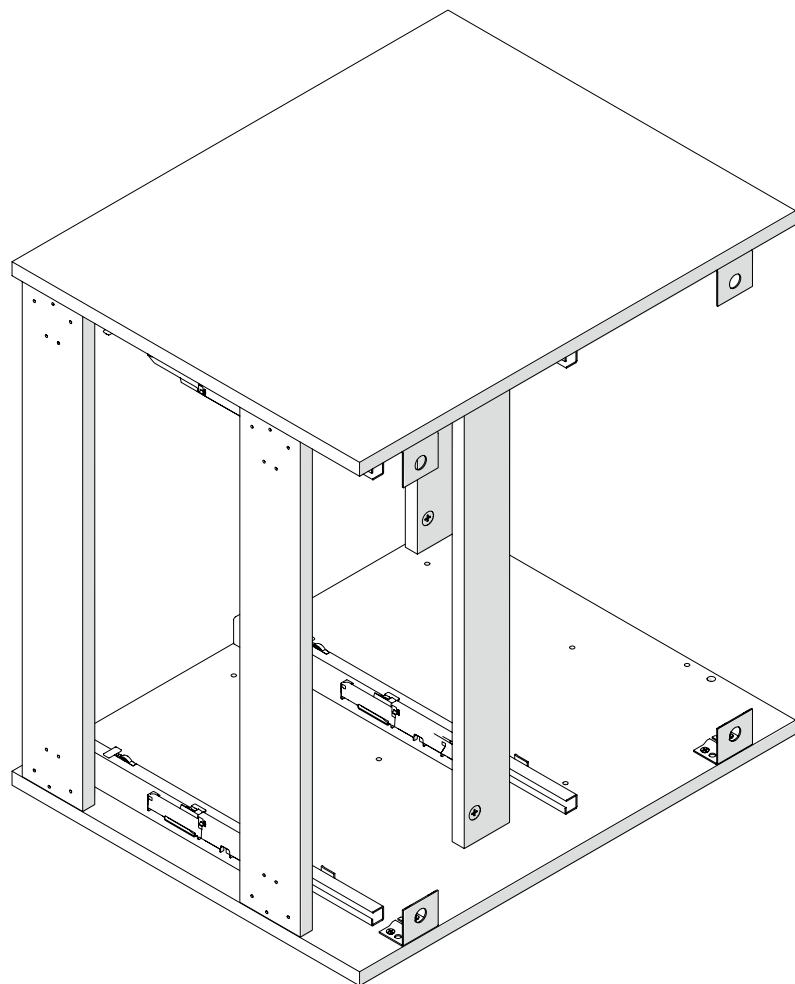

13

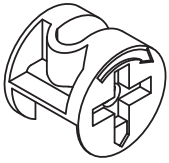

V
x 4



+

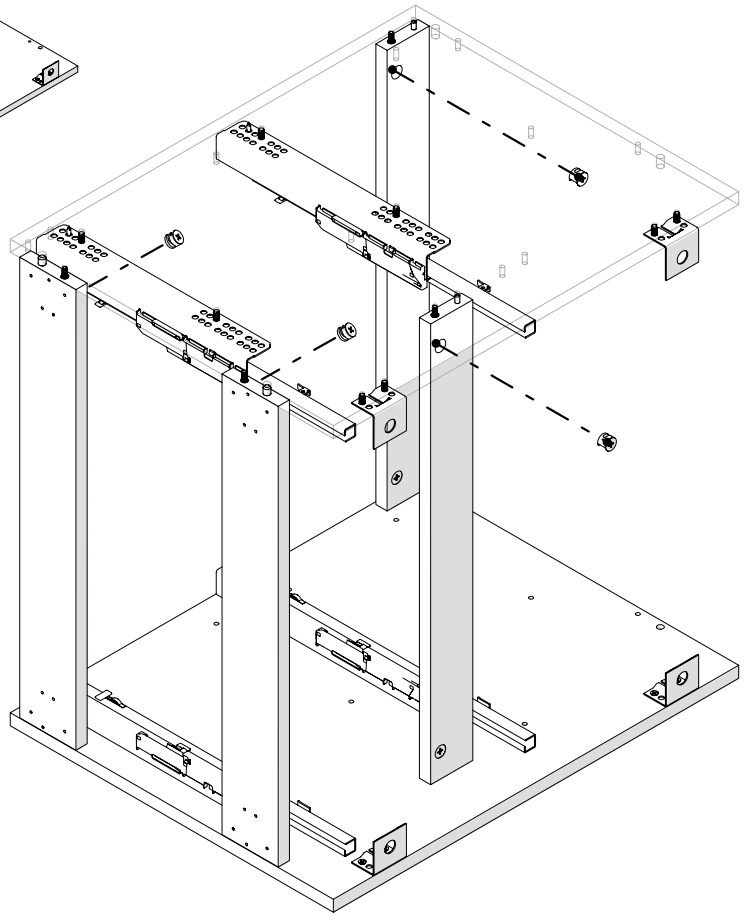
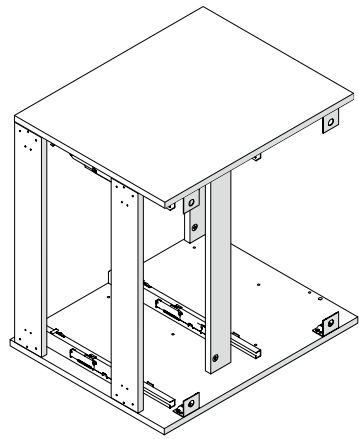
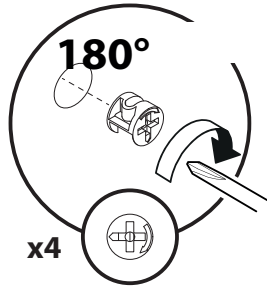

14

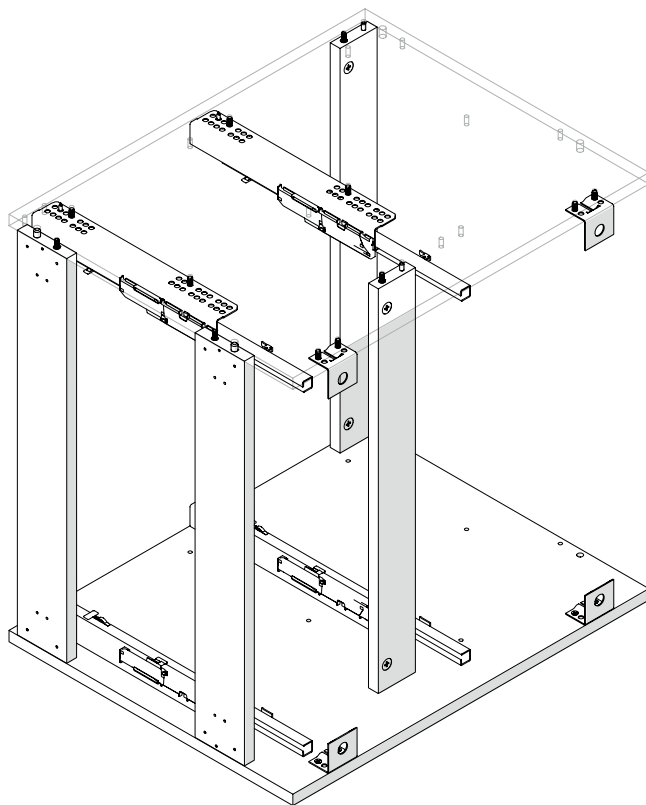

15

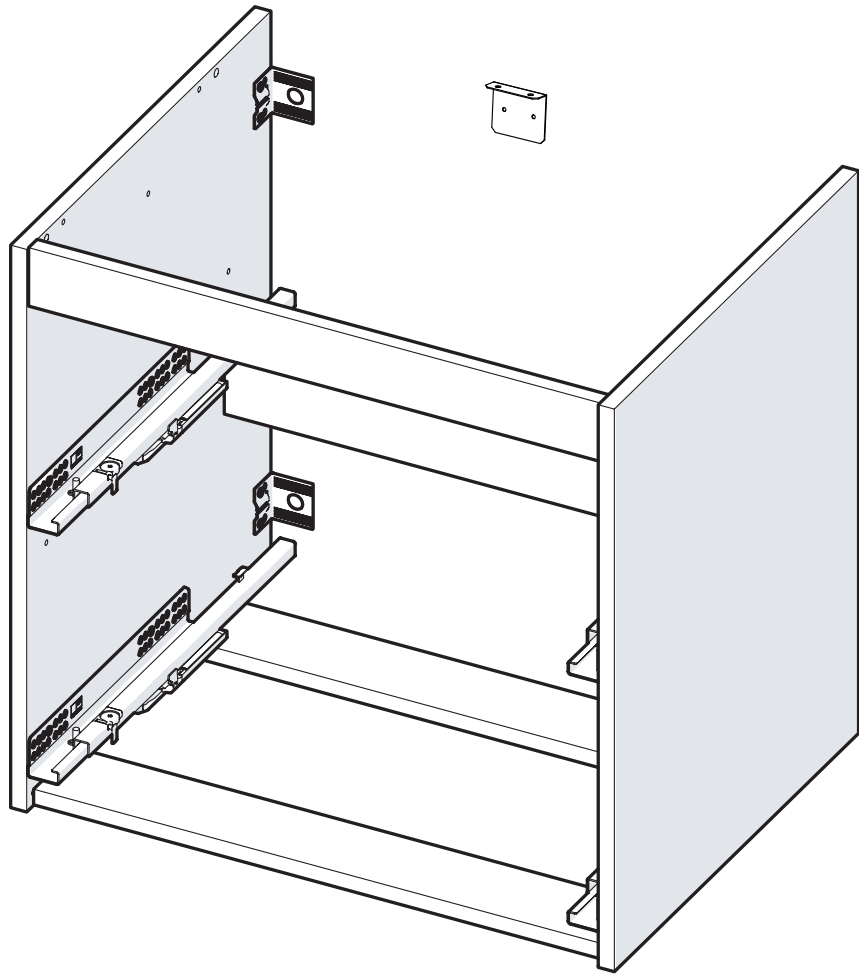

16

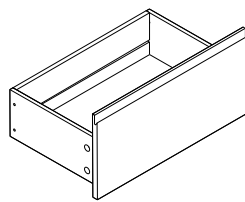
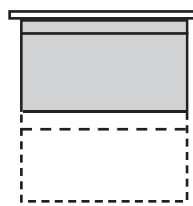

 17 → 20

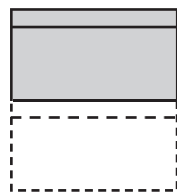

+

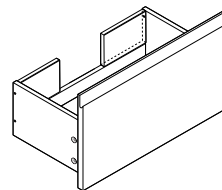

 21 → 26

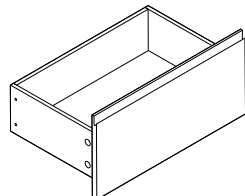
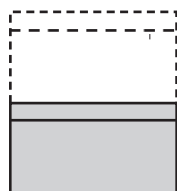

 27 → 30

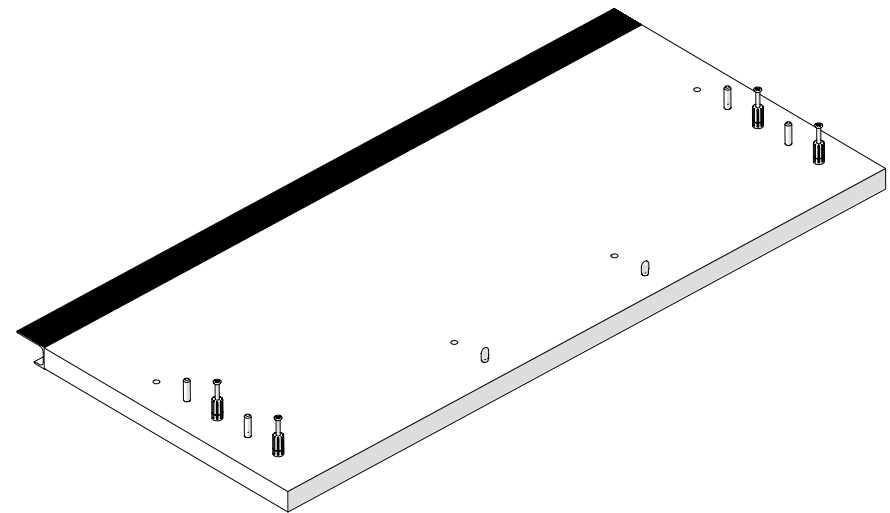
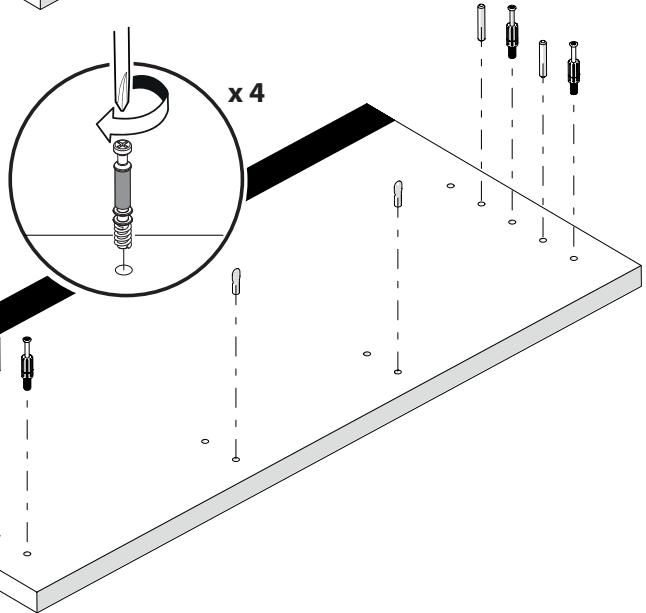
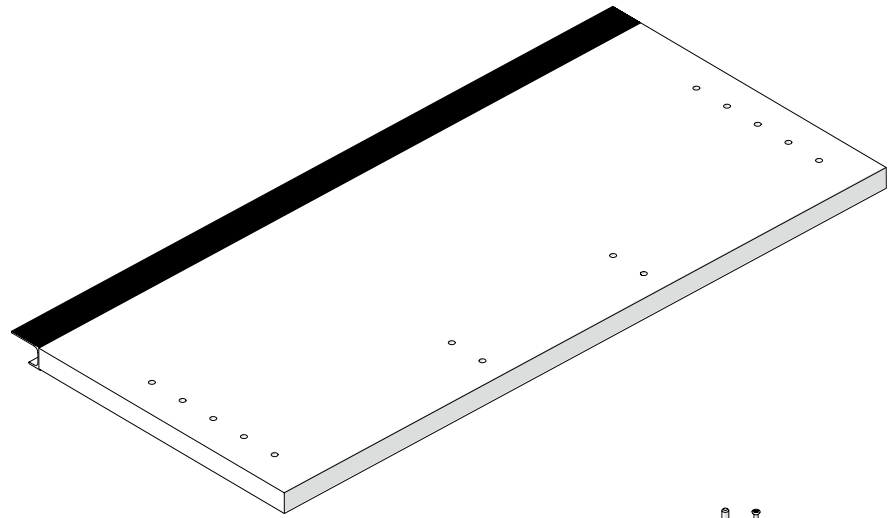
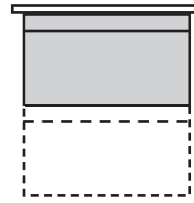
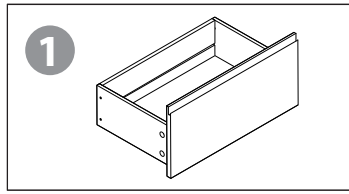
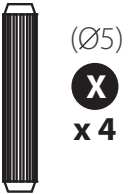
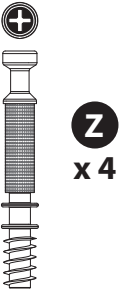



E
x 4

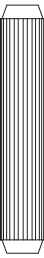

(Ø8)
Y
x 4

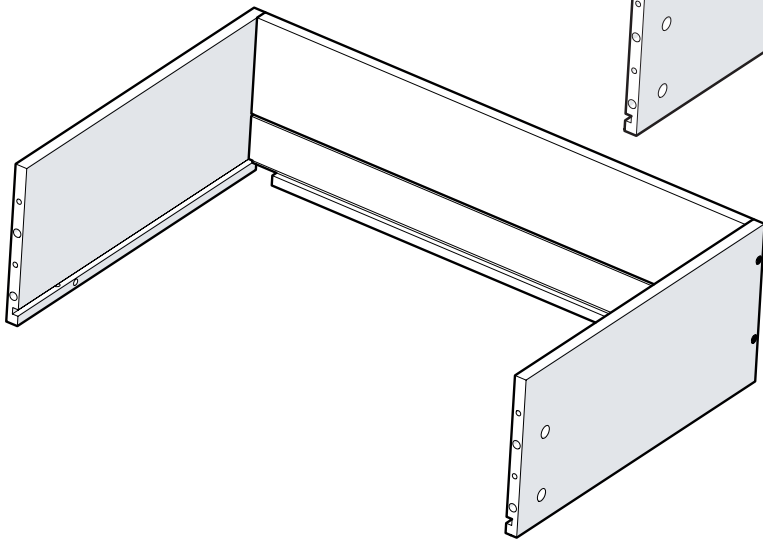
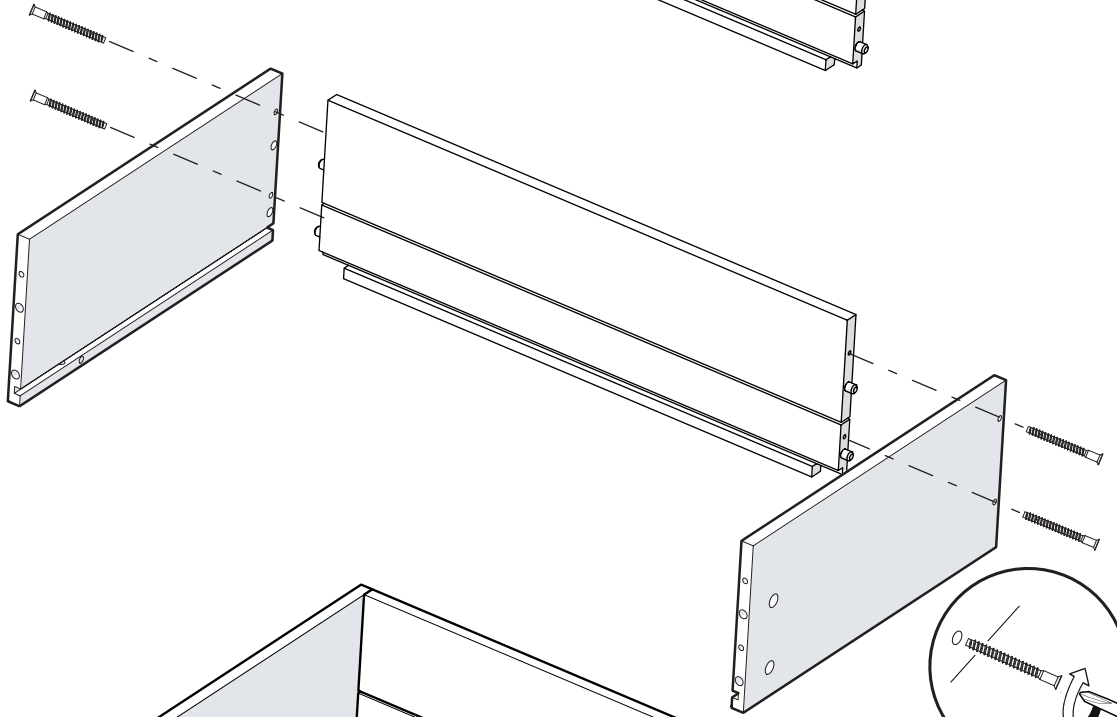
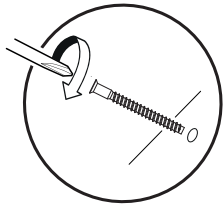
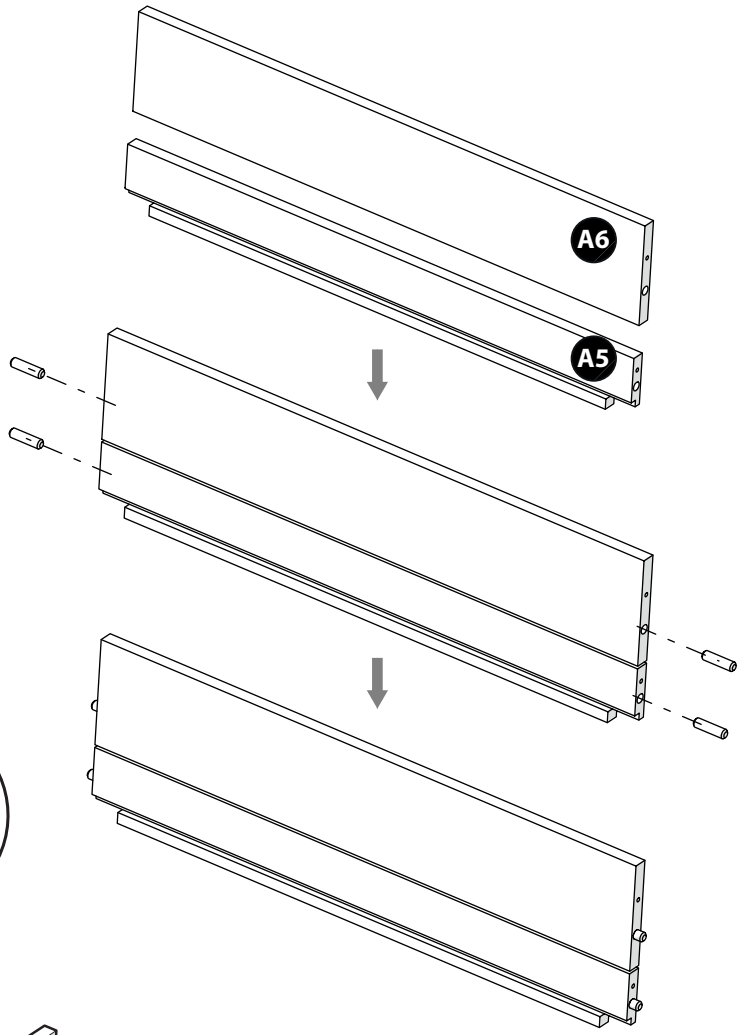
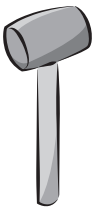

19

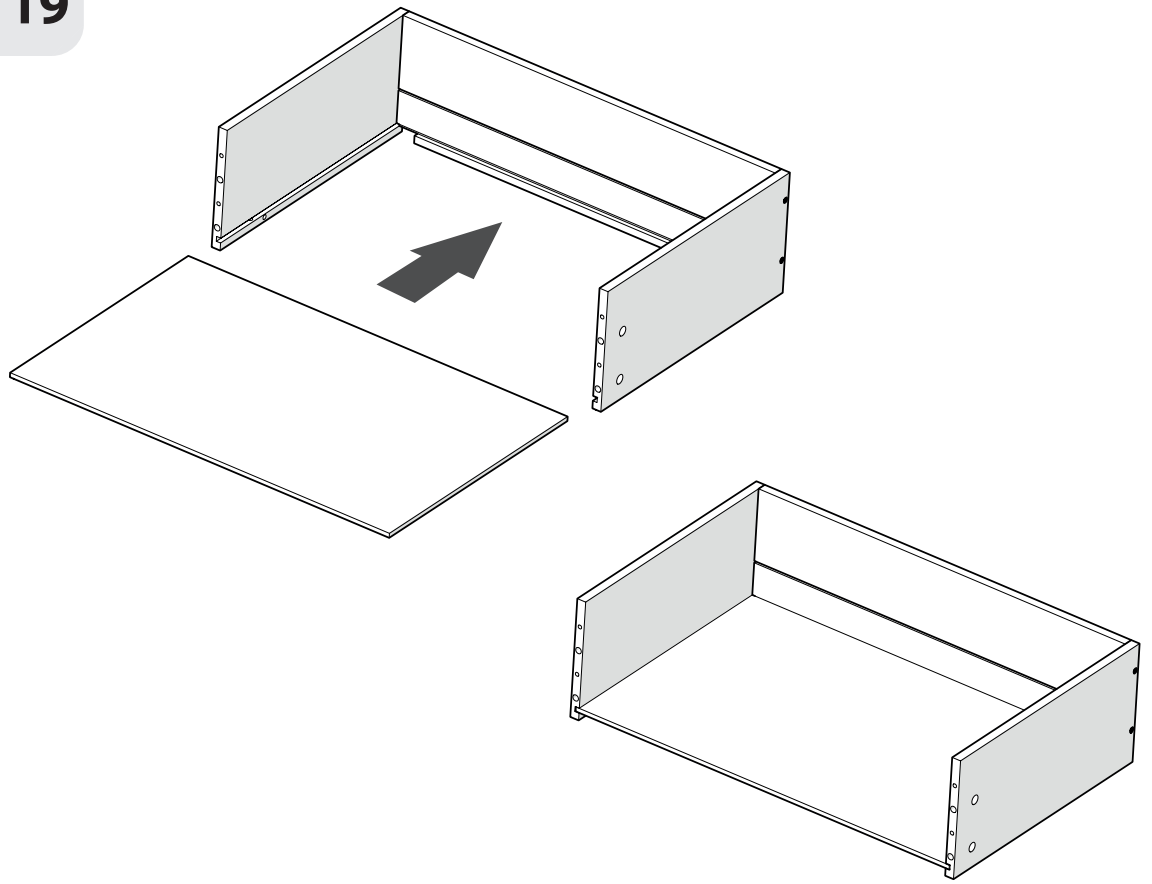

20

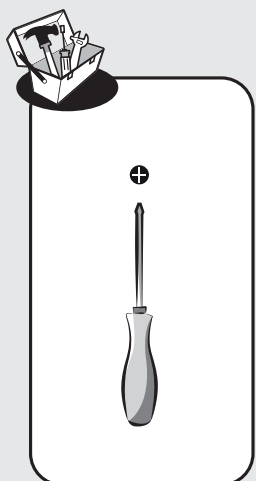
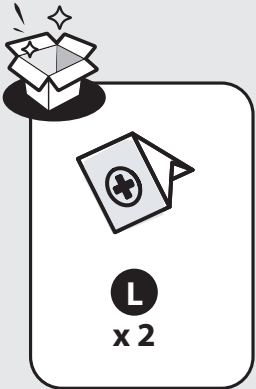
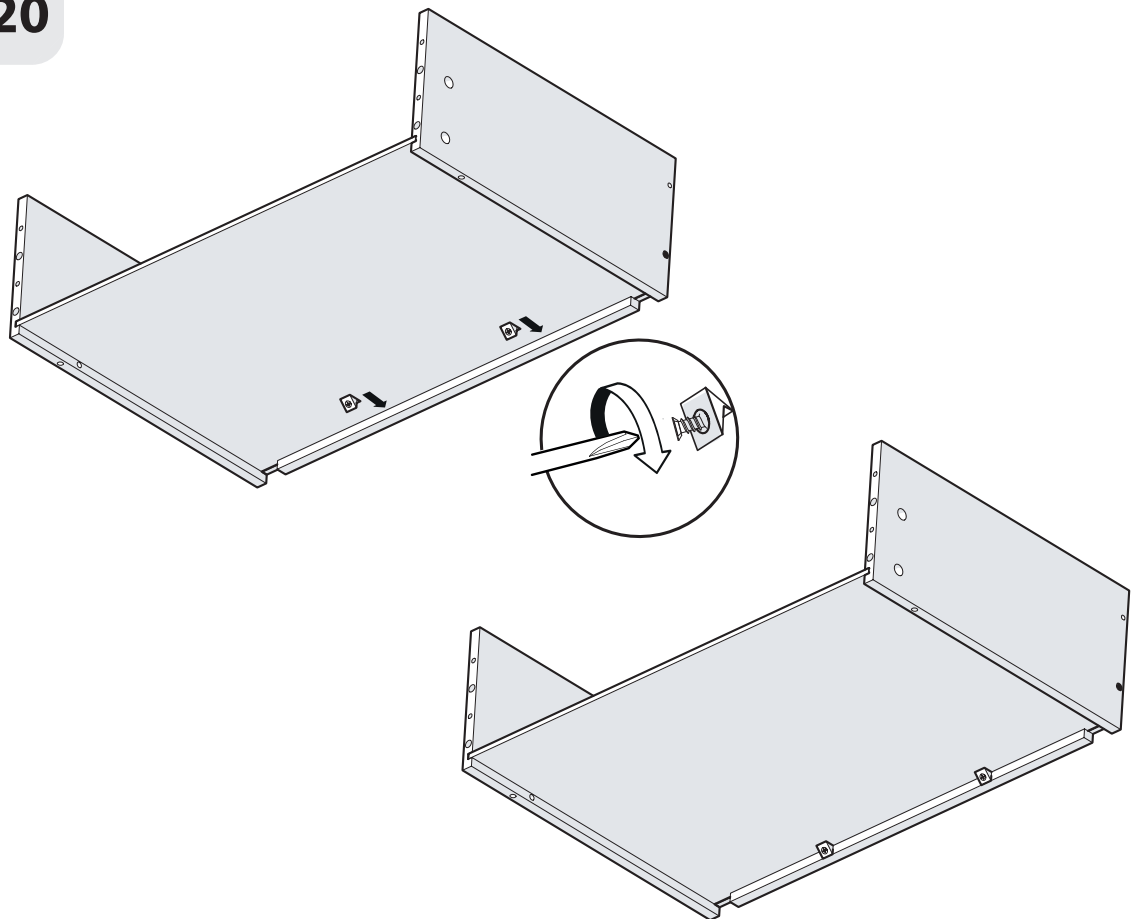

21

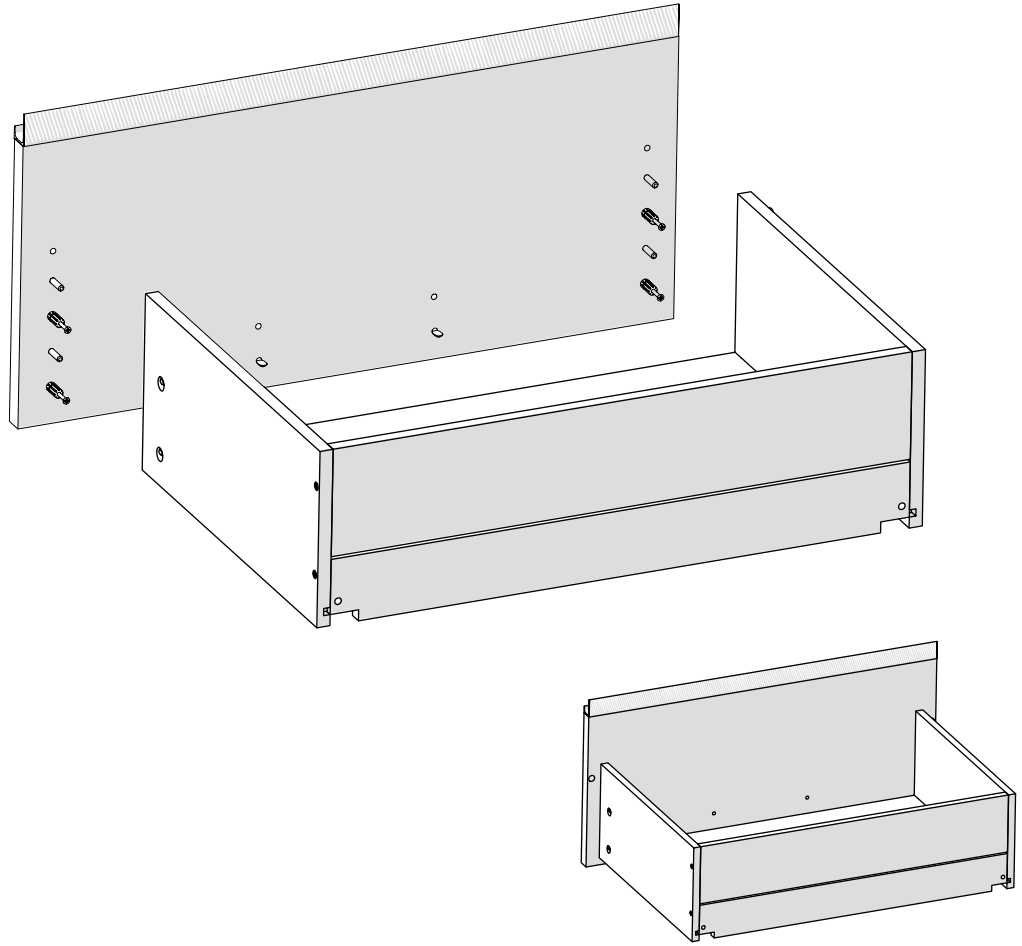

22

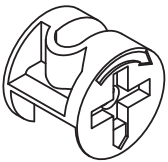
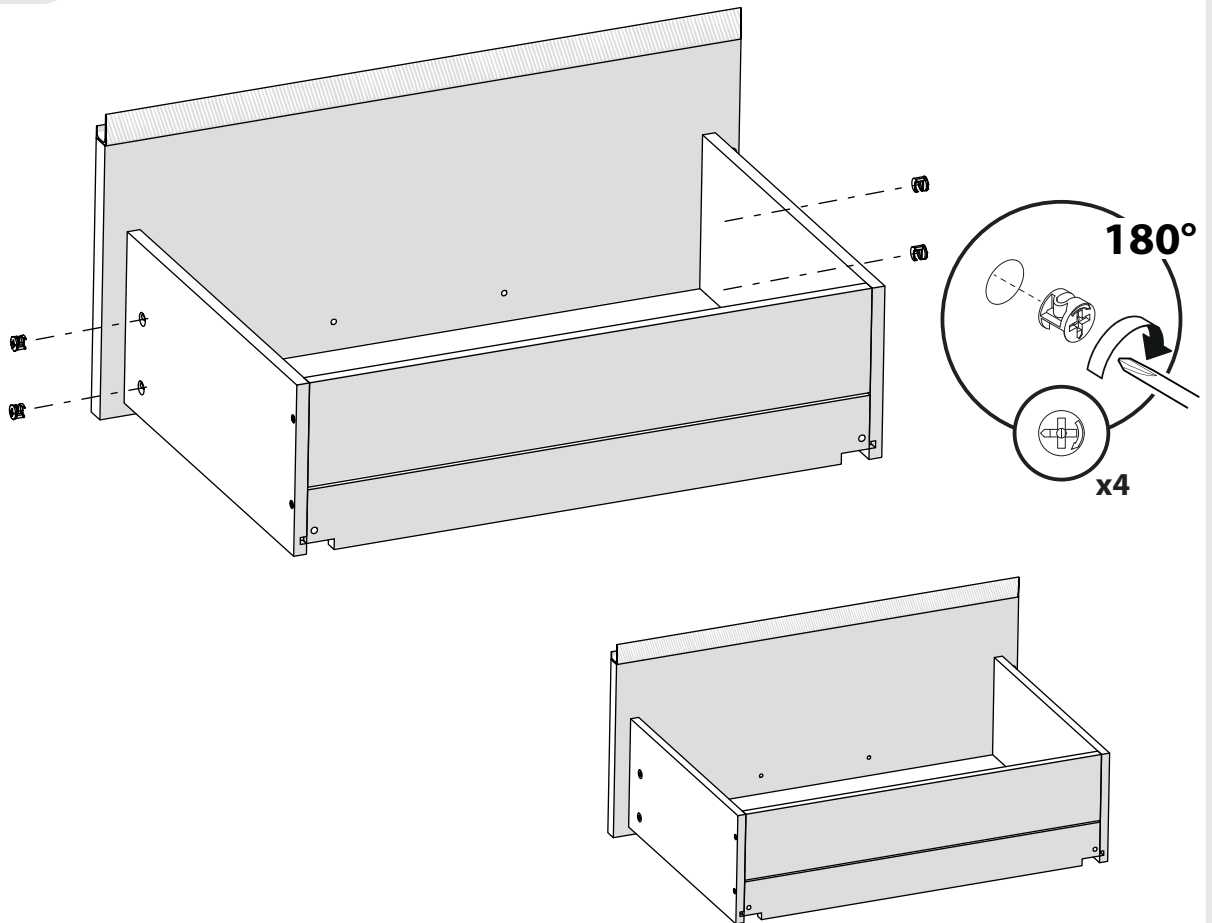

U
x 4



PZ2





Z
x 4



(Ø5)
X
x 4



M
x 2

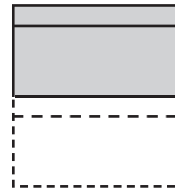
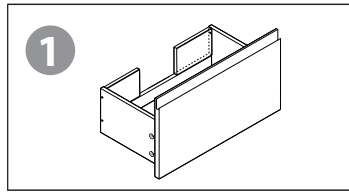

+

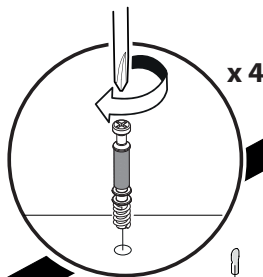
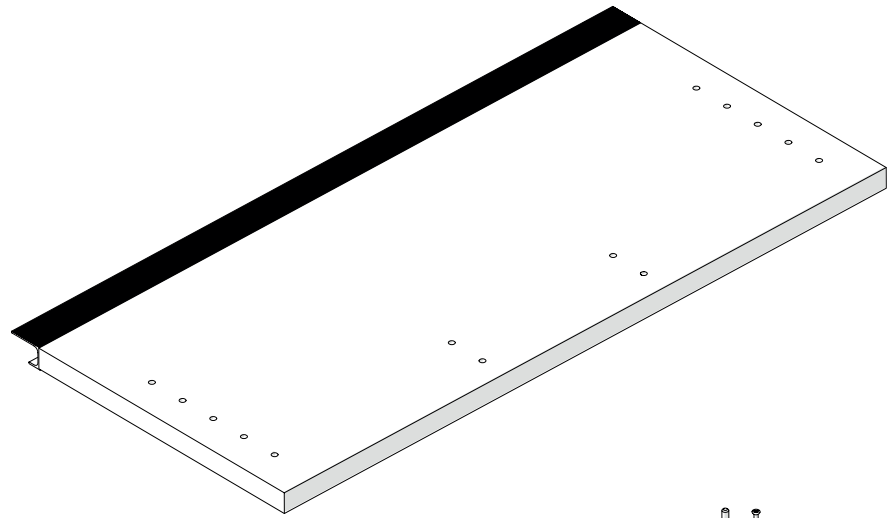

x 4

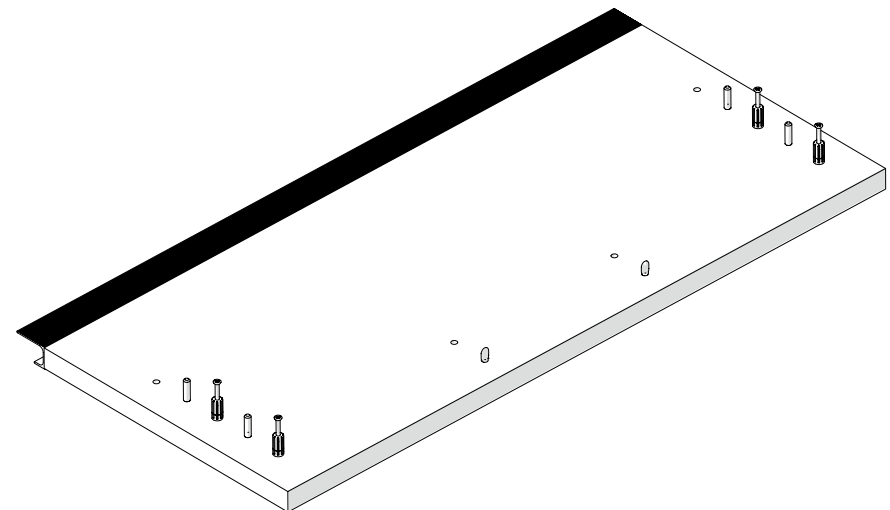
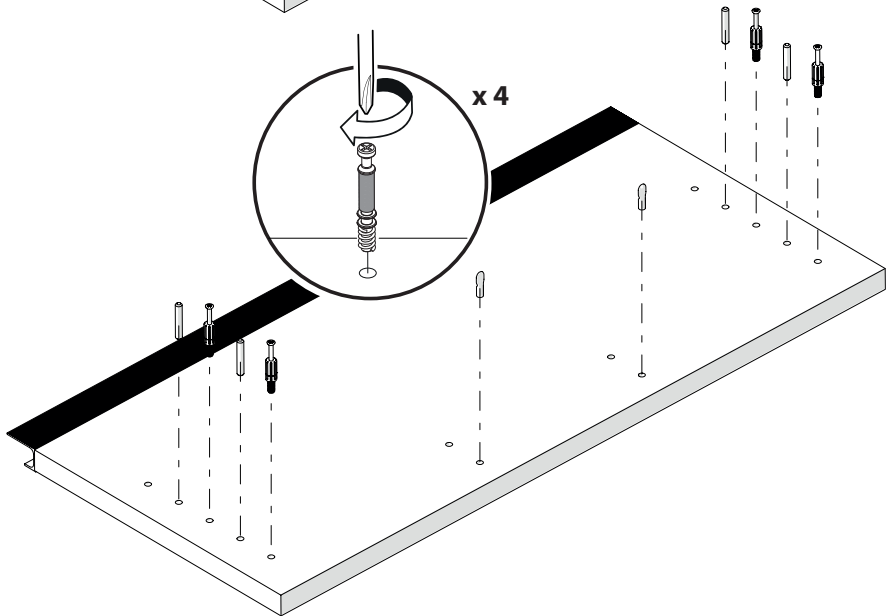



E
x 2



(Ø8)

Y
x 2

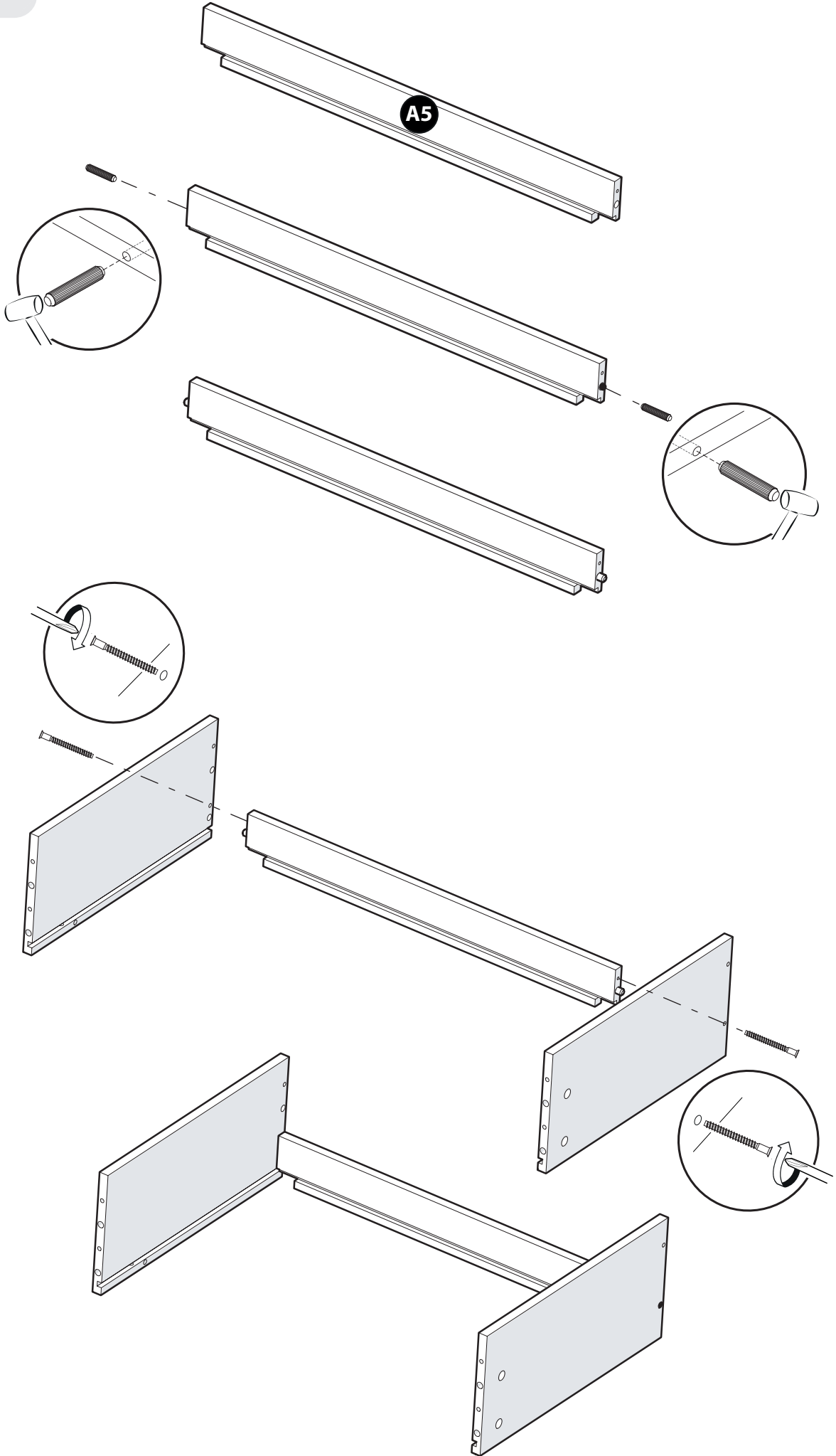
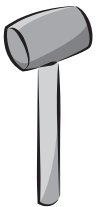

25

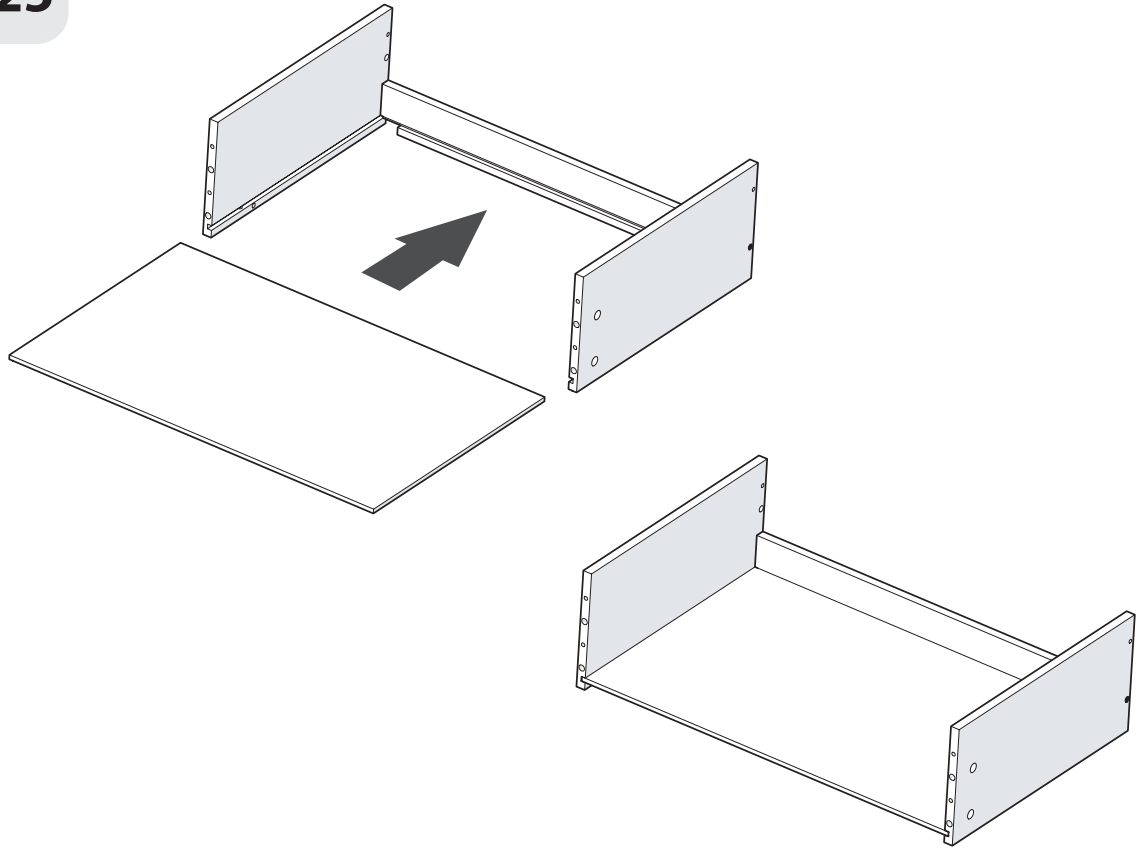

26

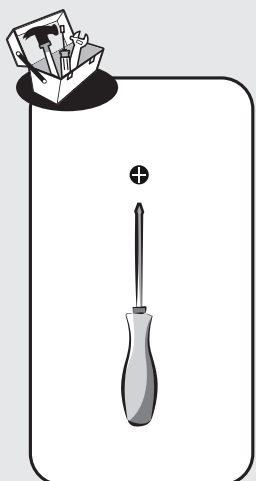
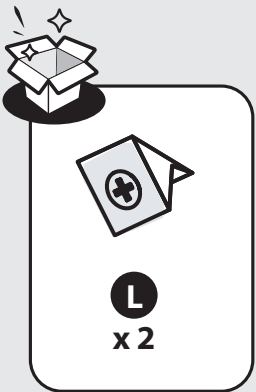
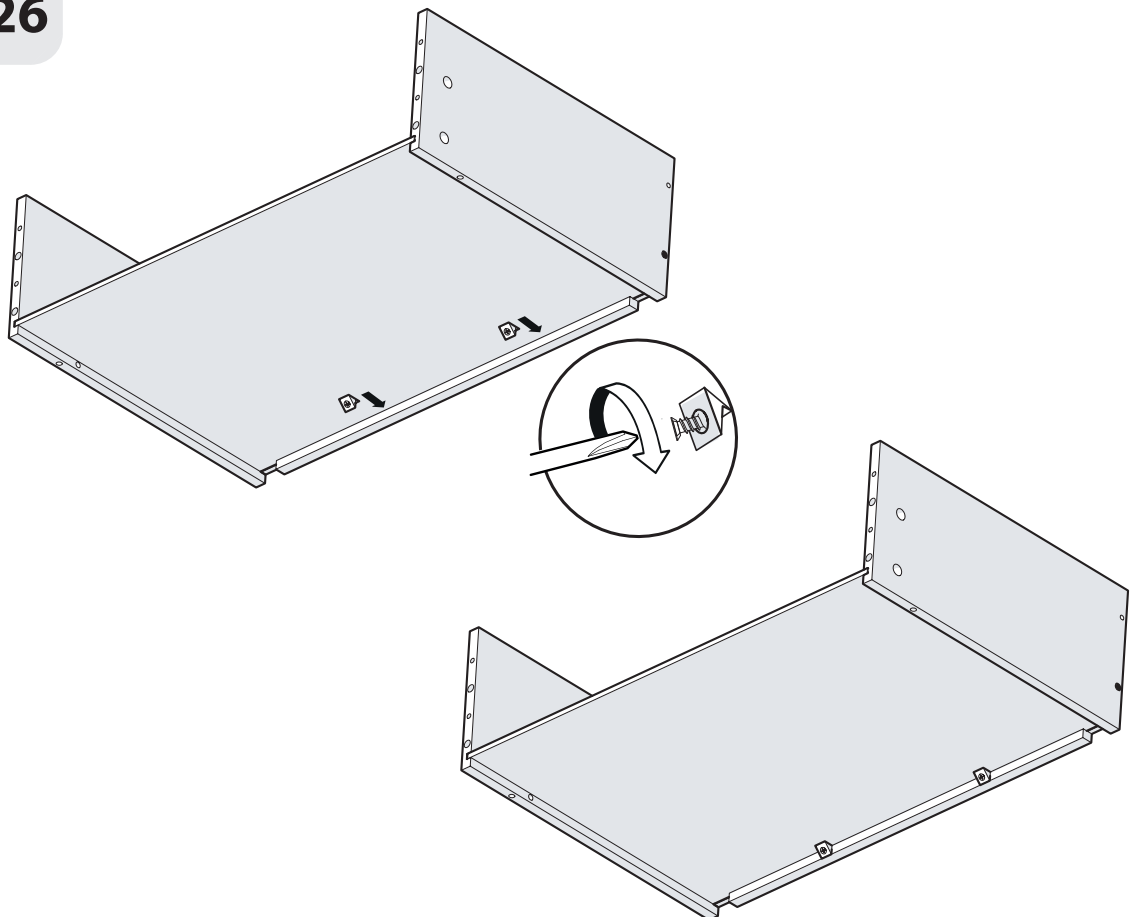

27

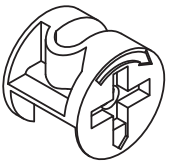
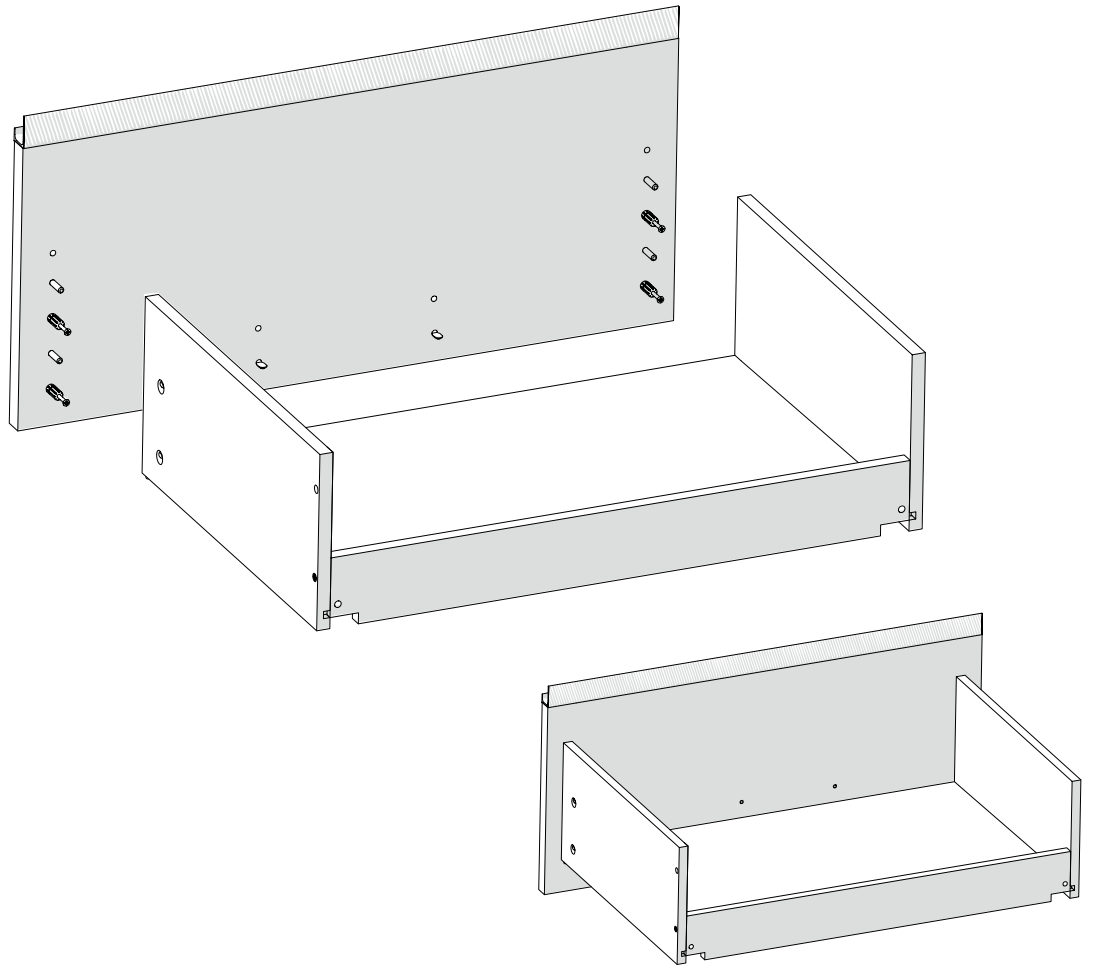

U
x 4

28

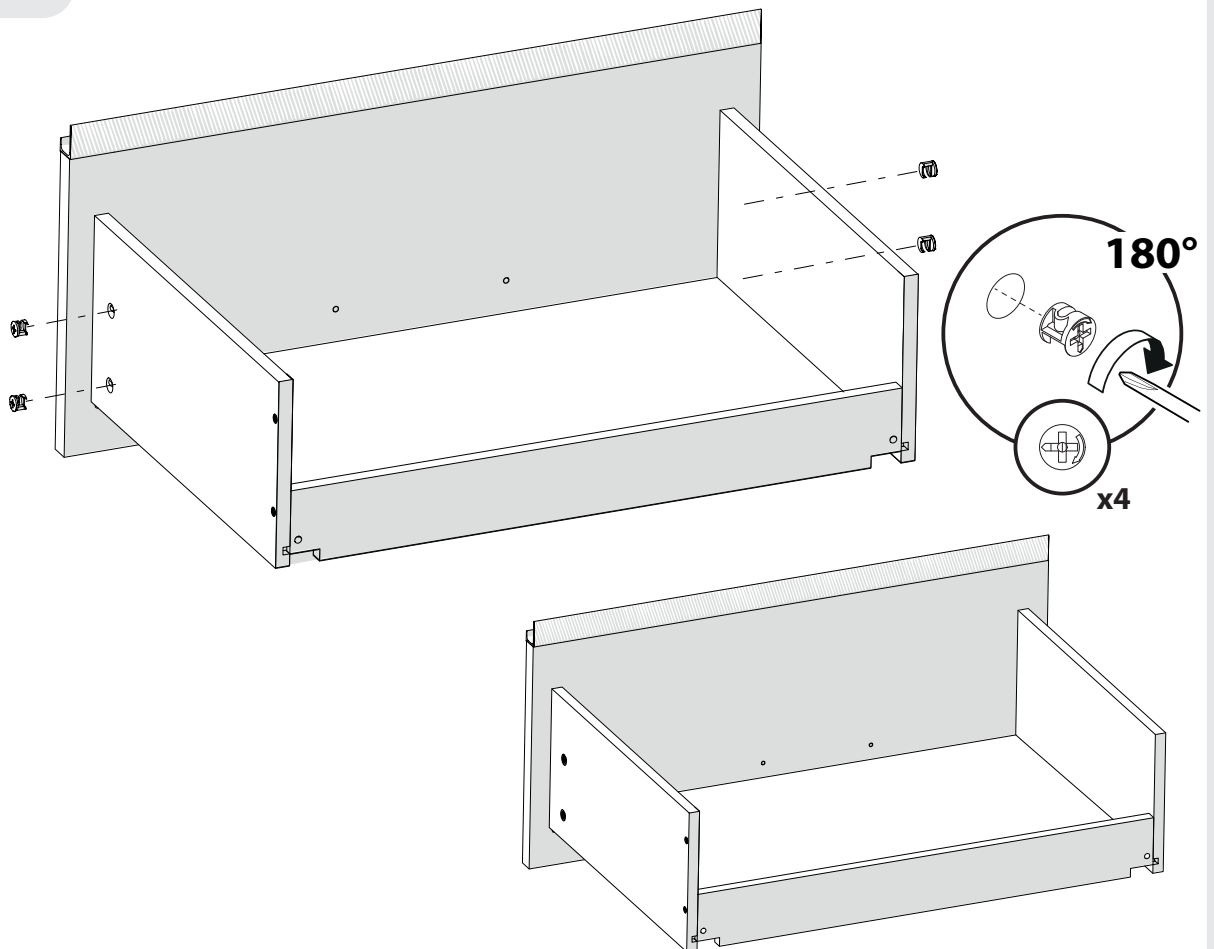

PZ2



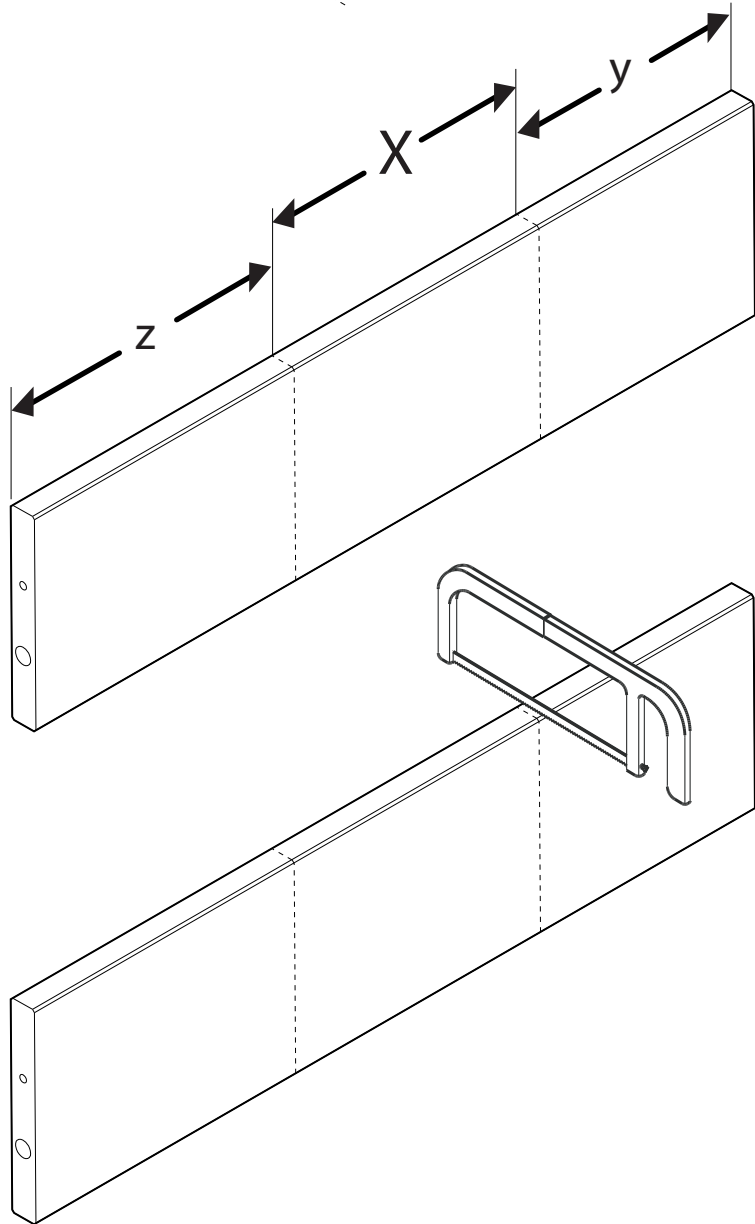
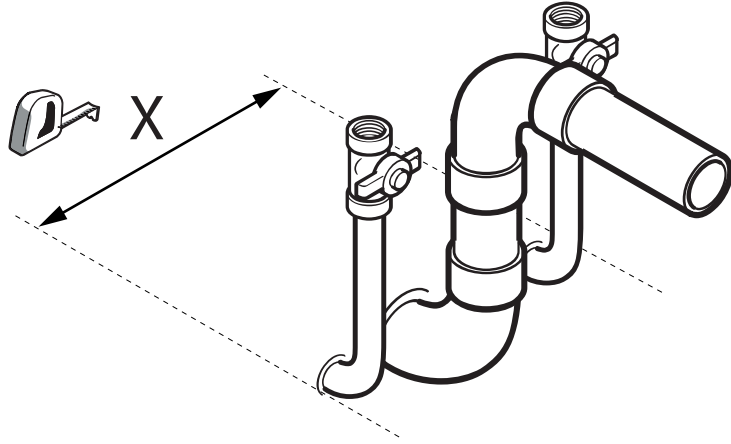
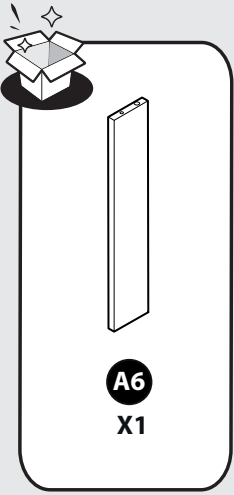

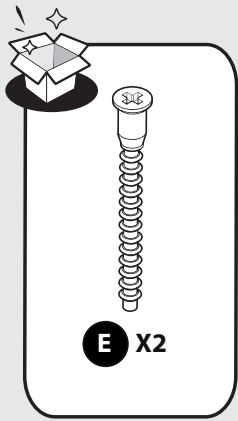

30

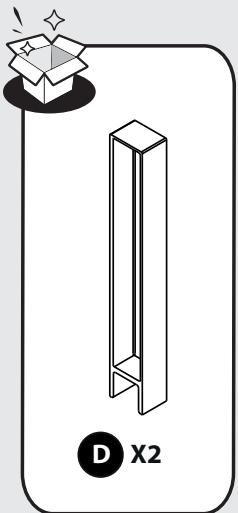
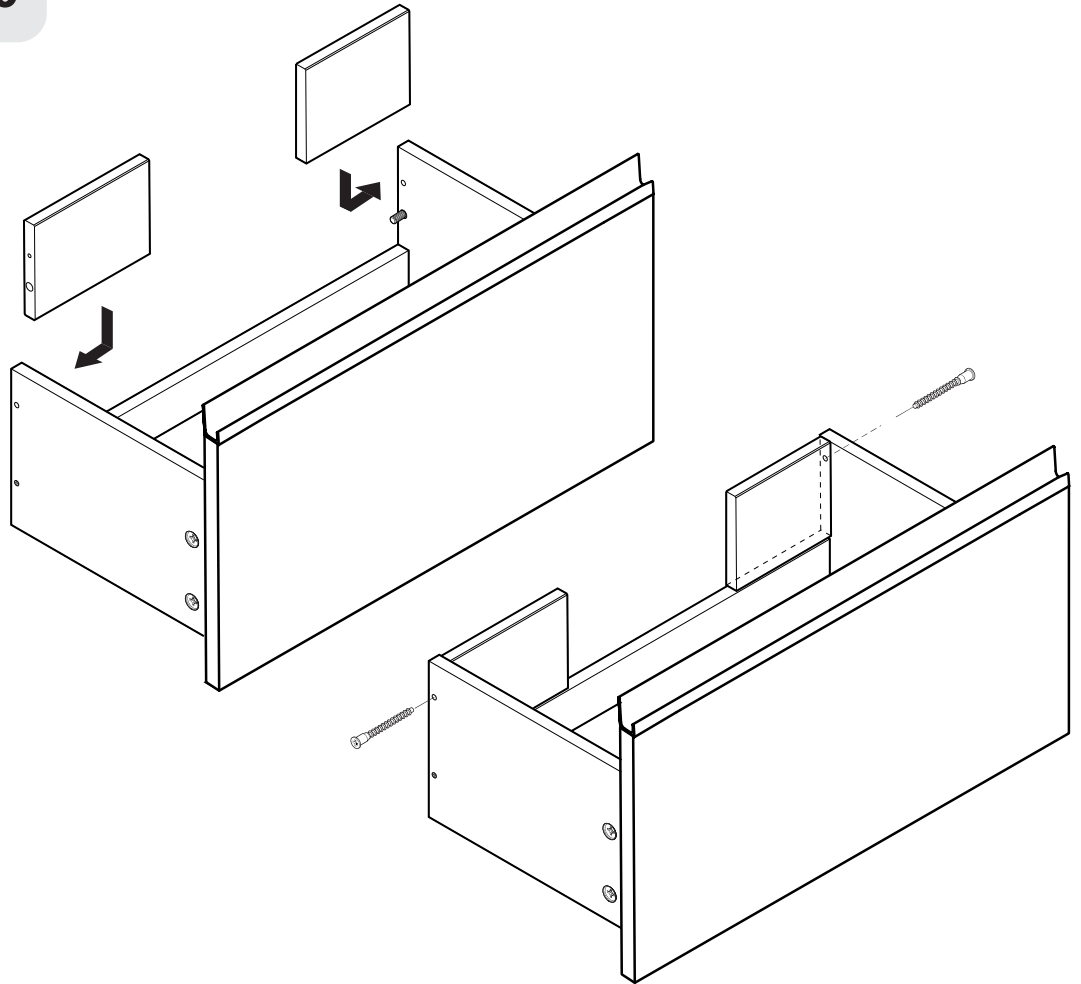

31

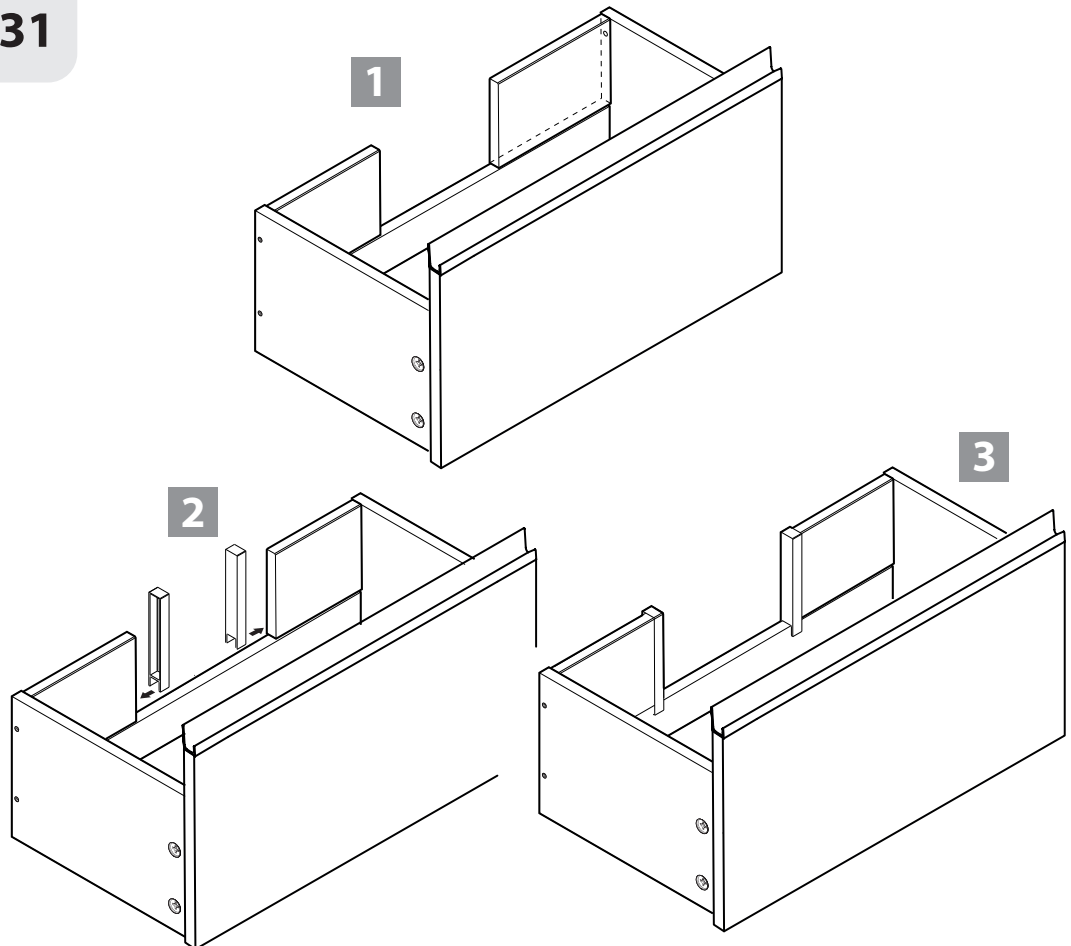



Z
x 4



X
x 4



M
x 2

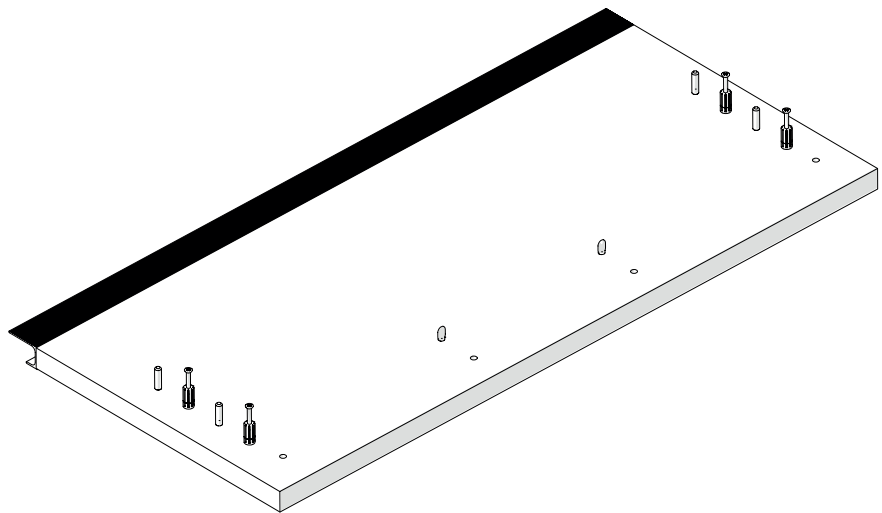
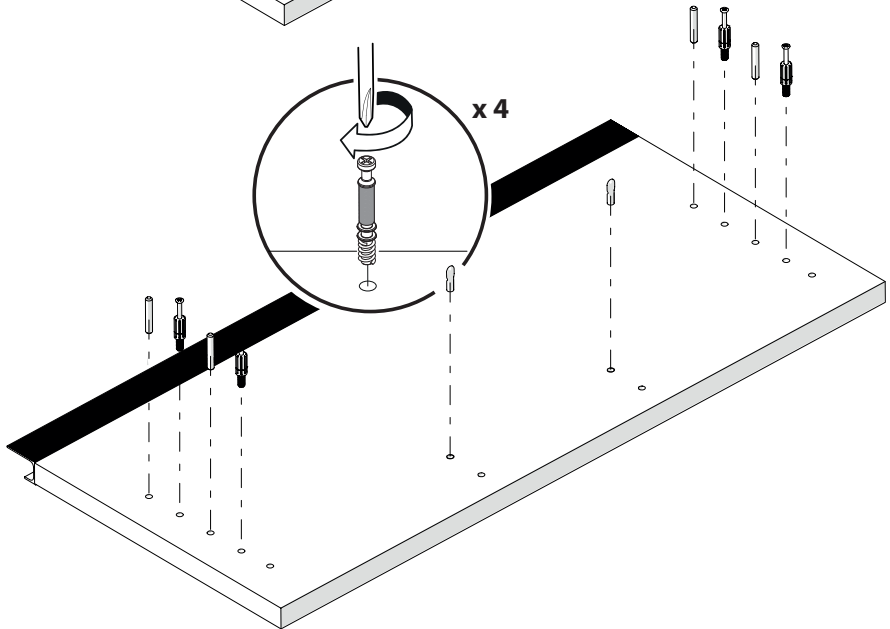
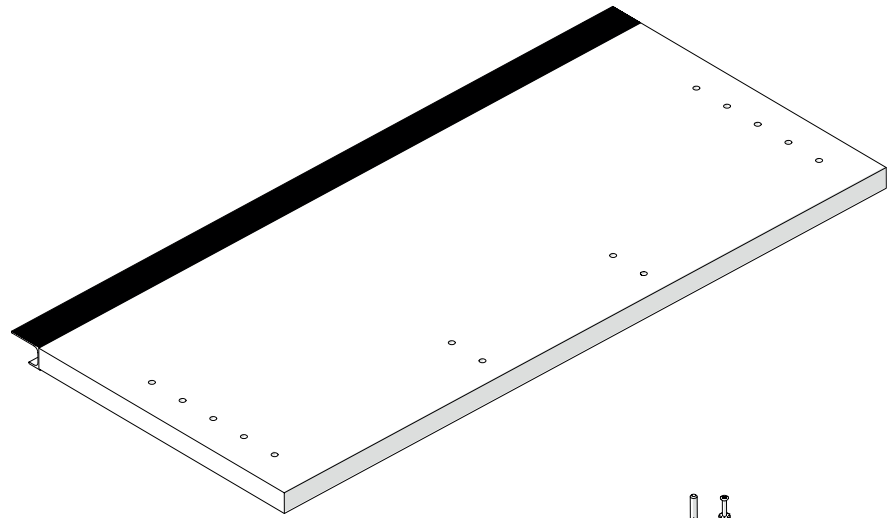
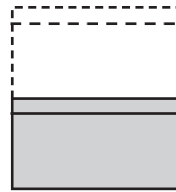
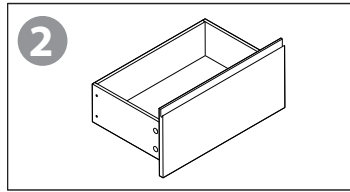

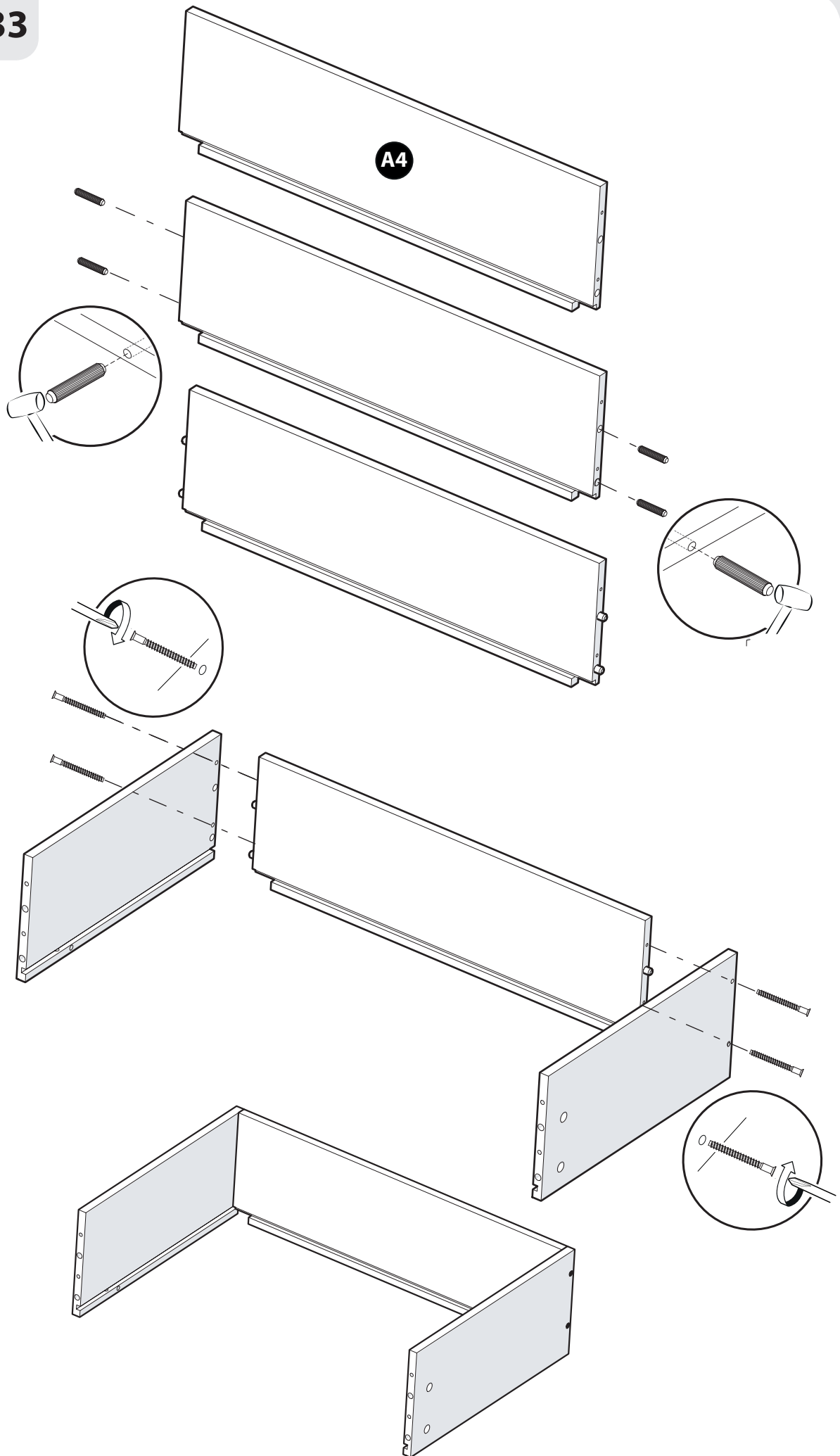
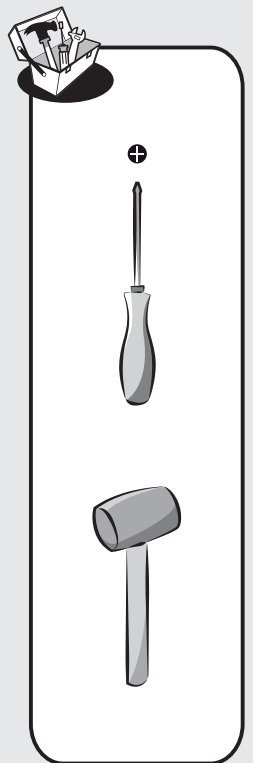
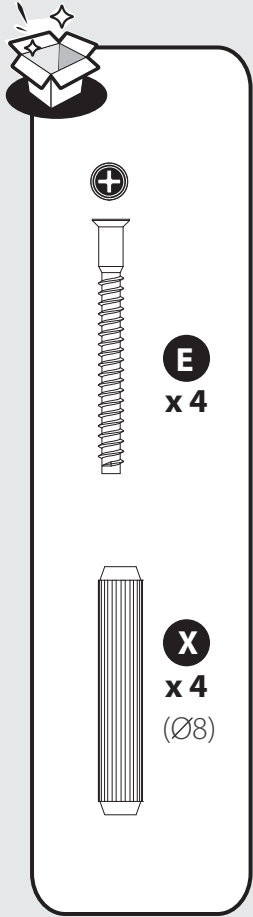

34

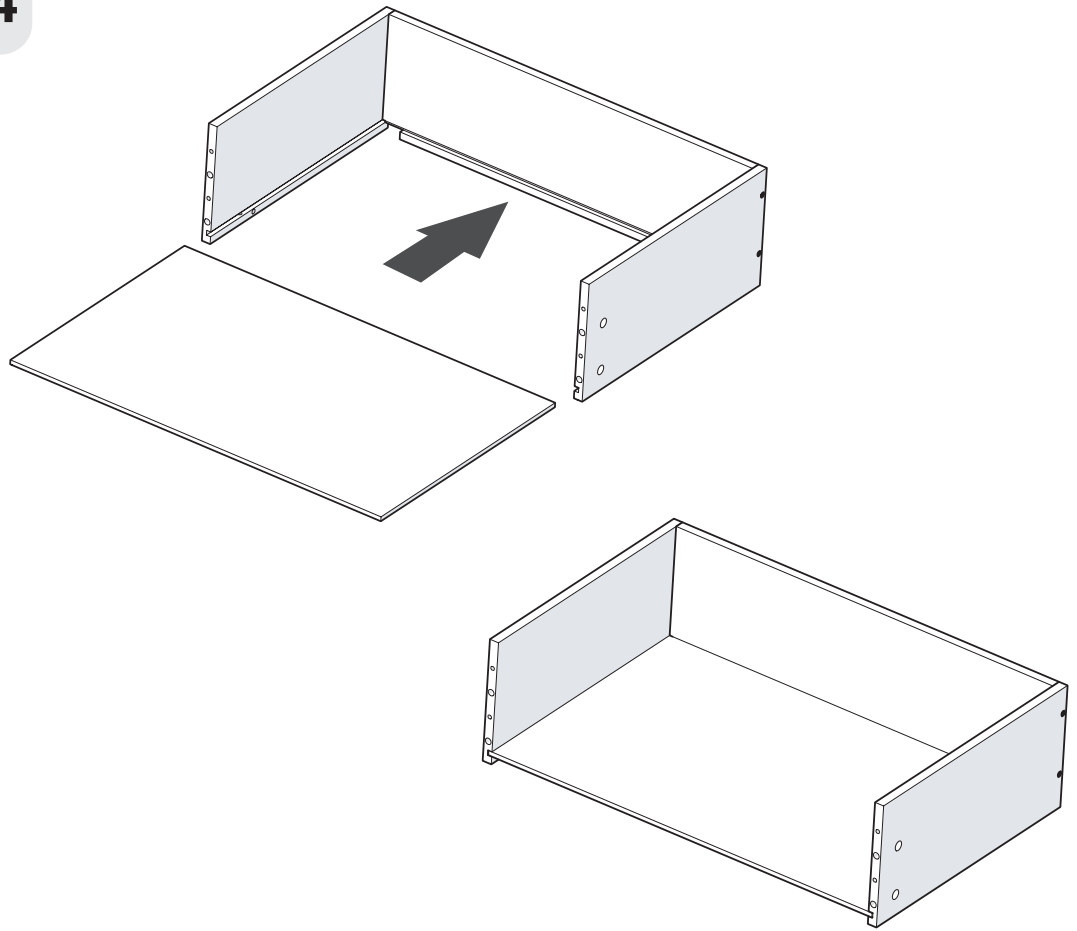

35

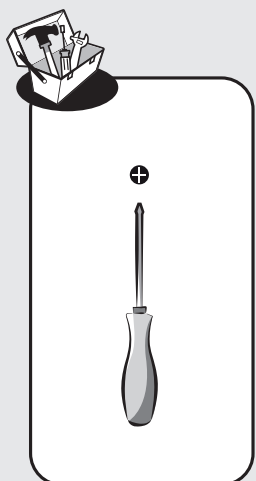
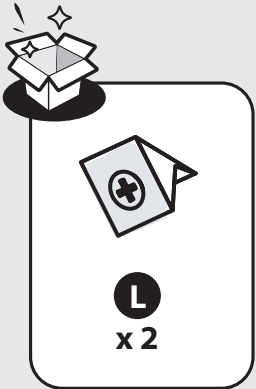
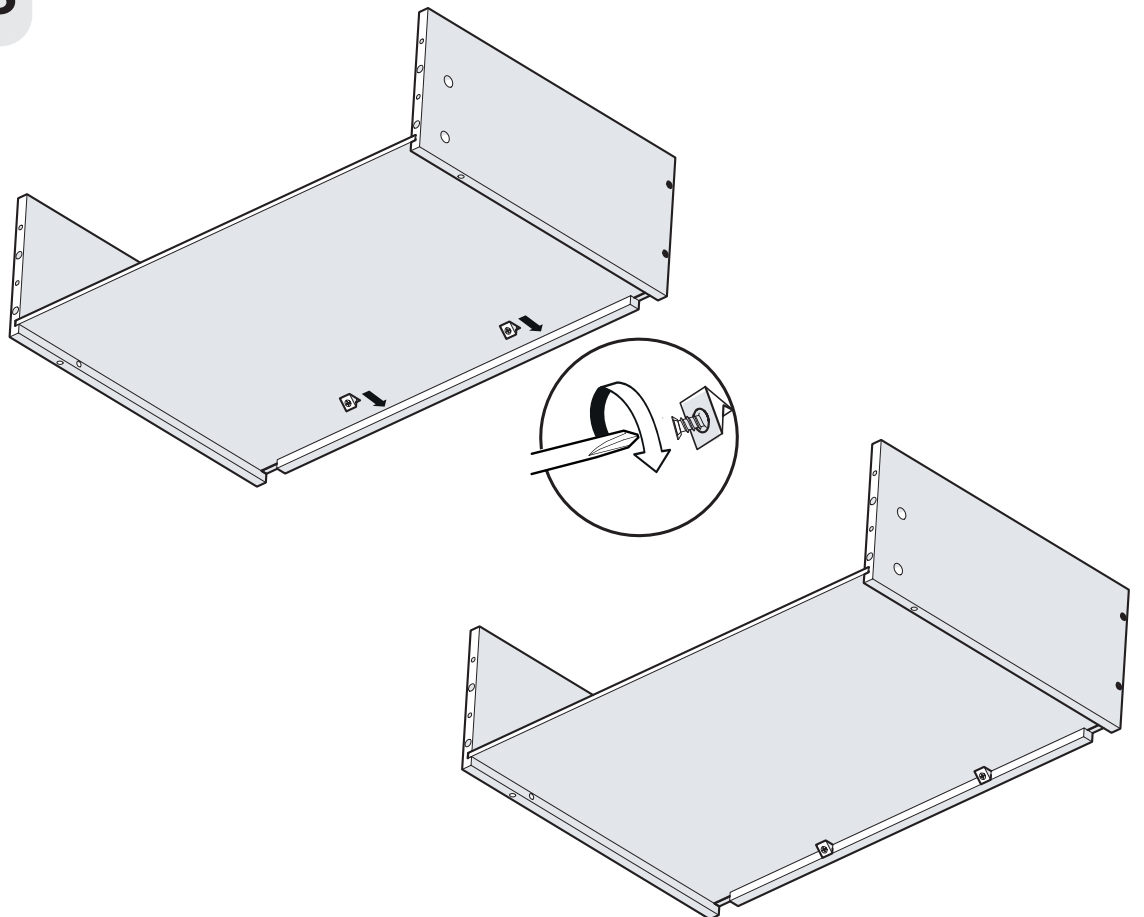

36

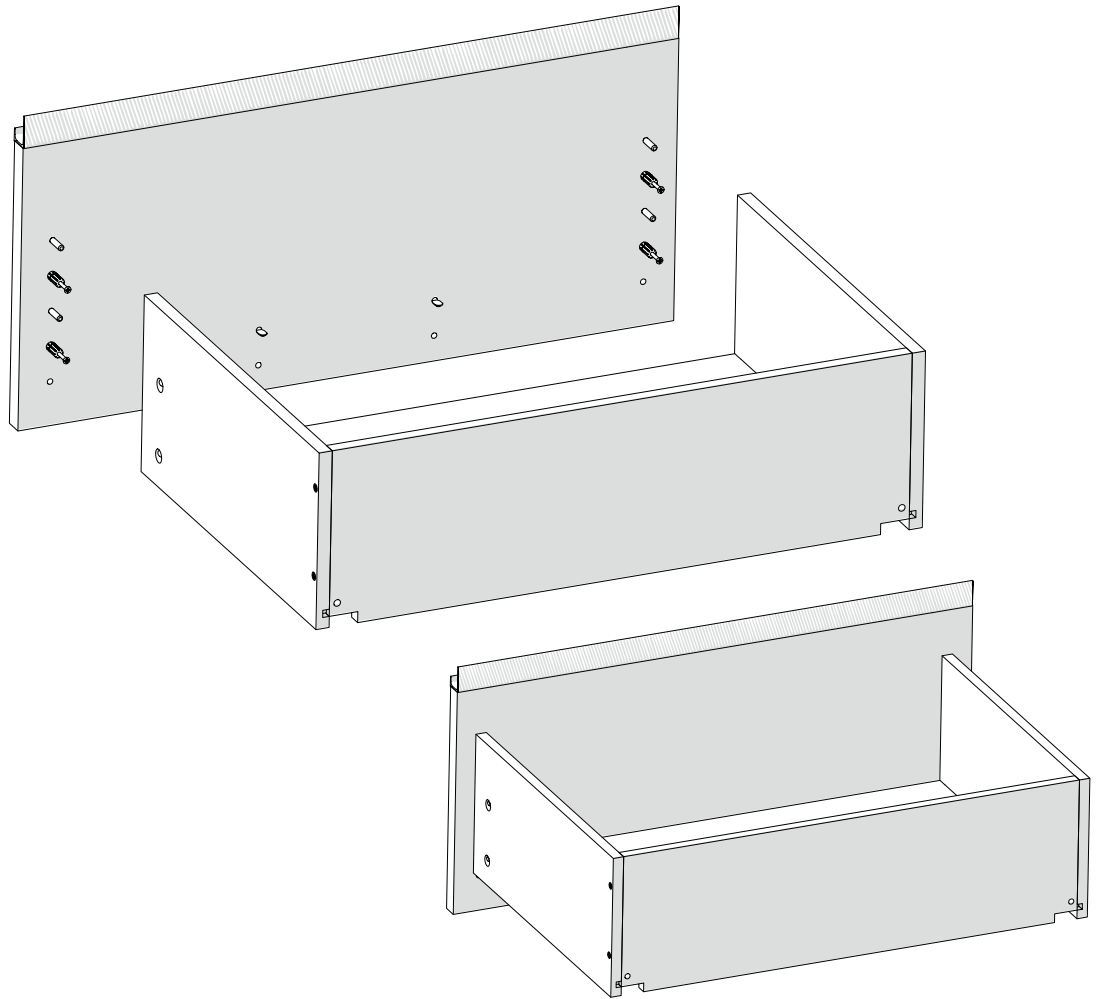

37

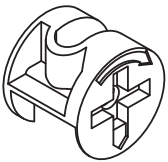
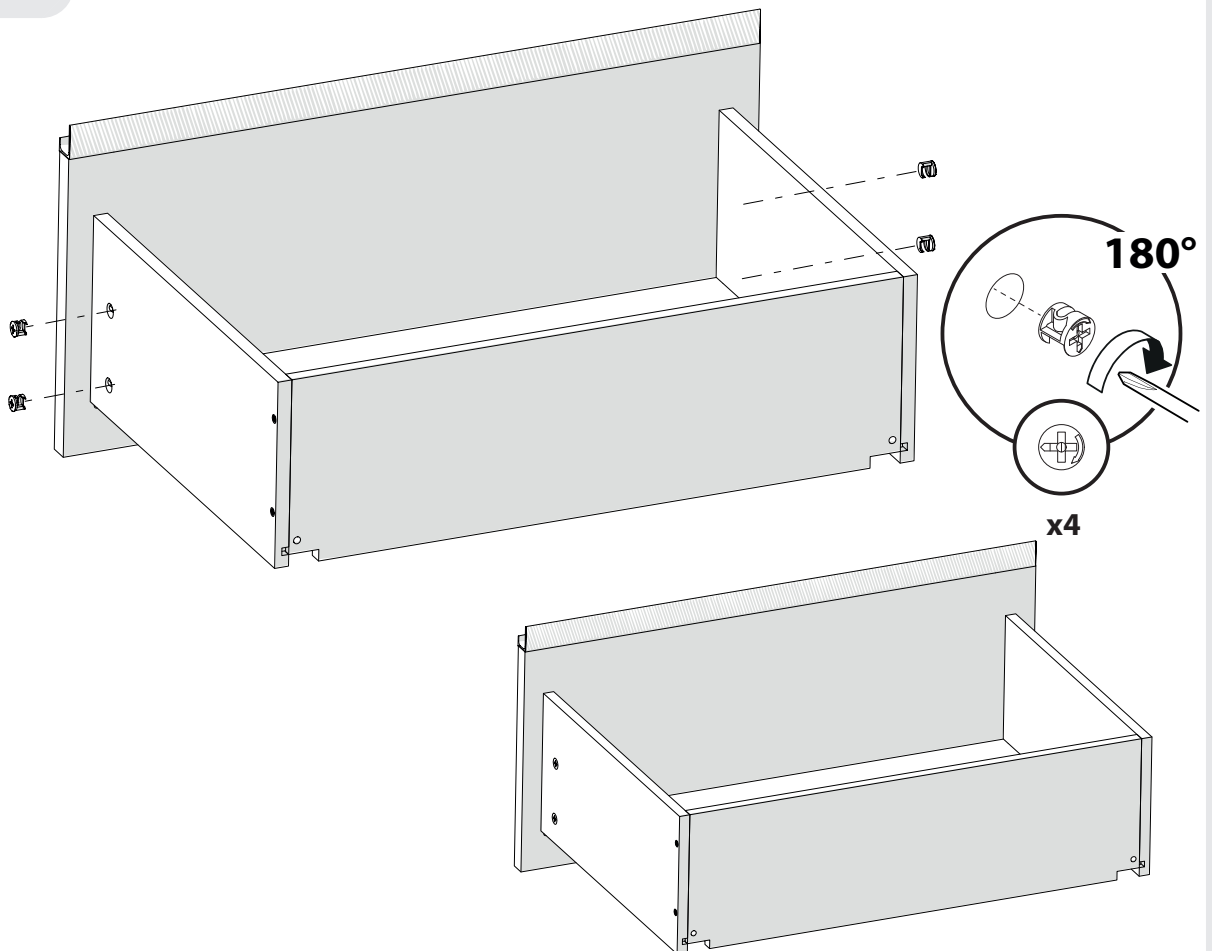



U
x 4



PZ2

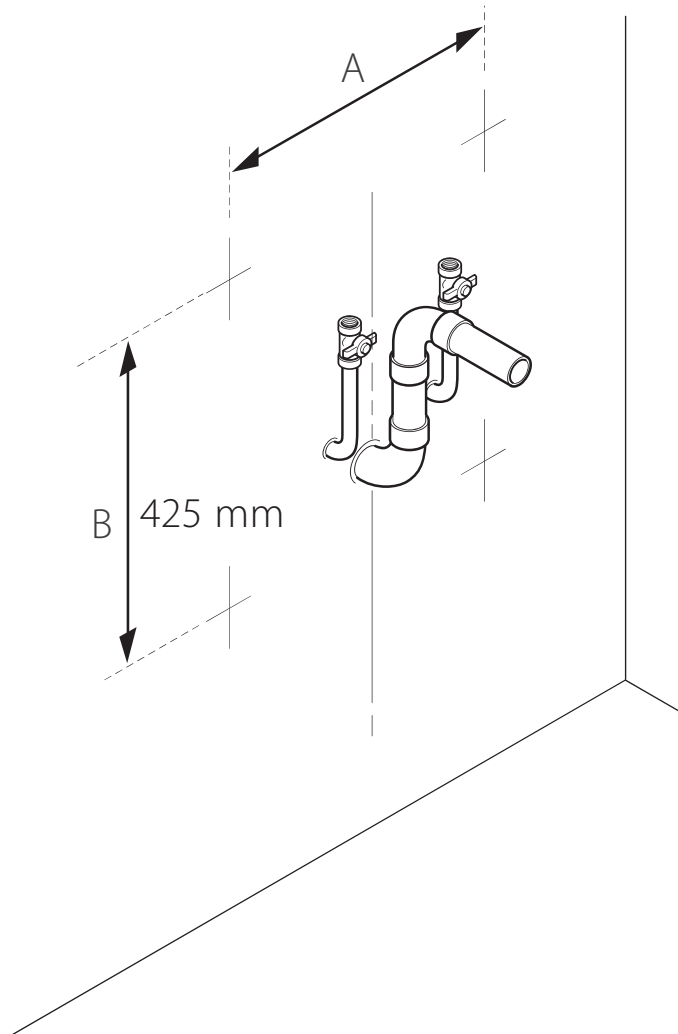
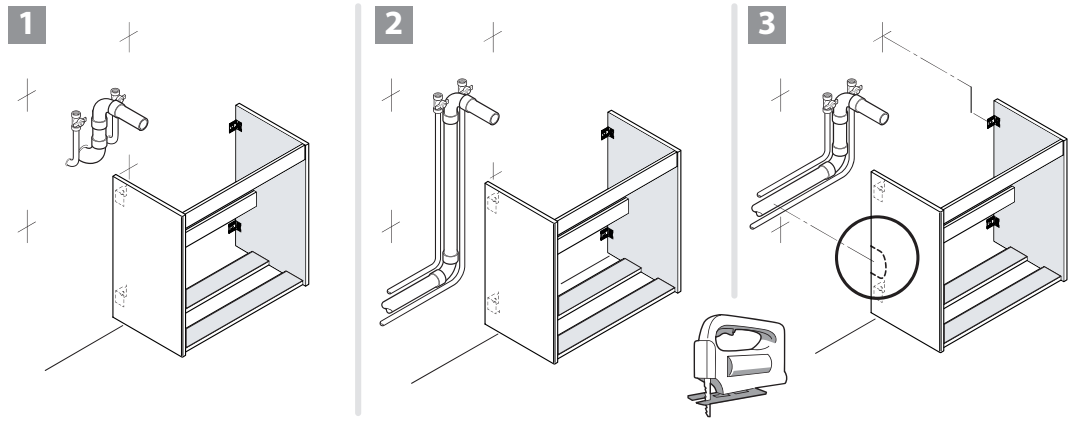



	60 cm	90 cm
		
A	520 mm	820 mm

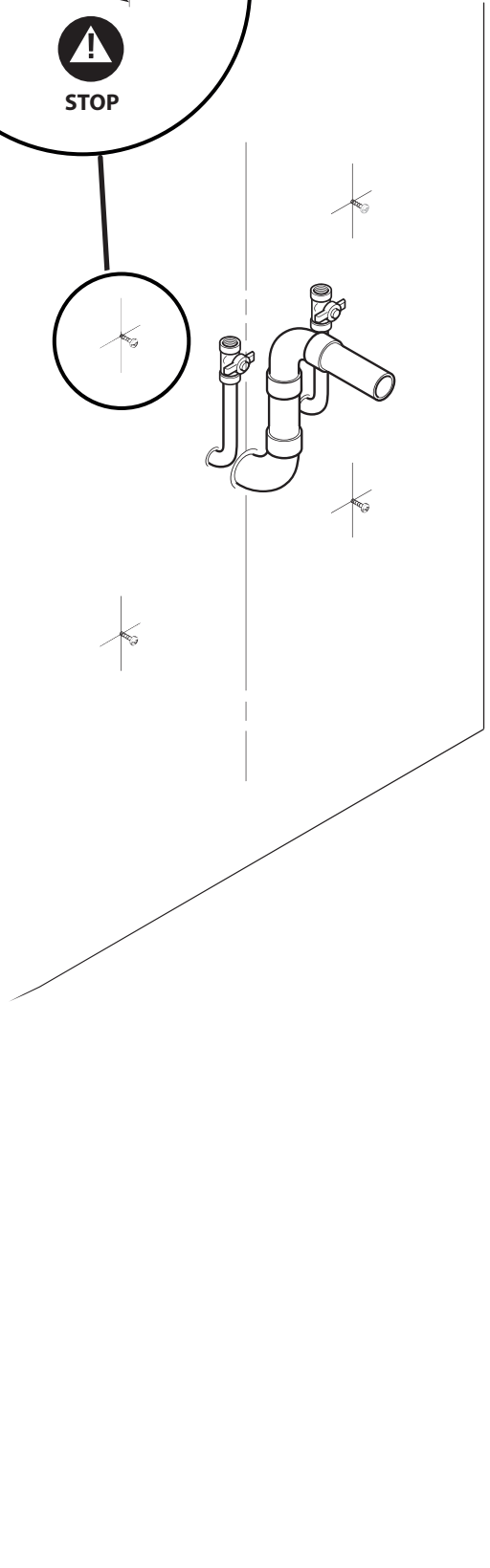
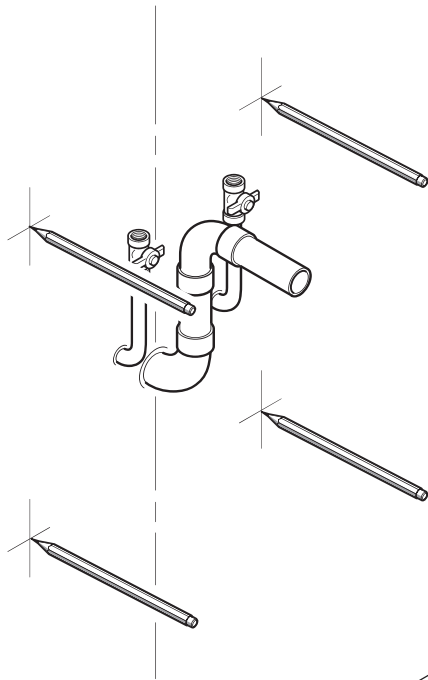
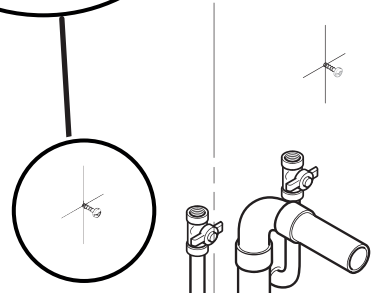
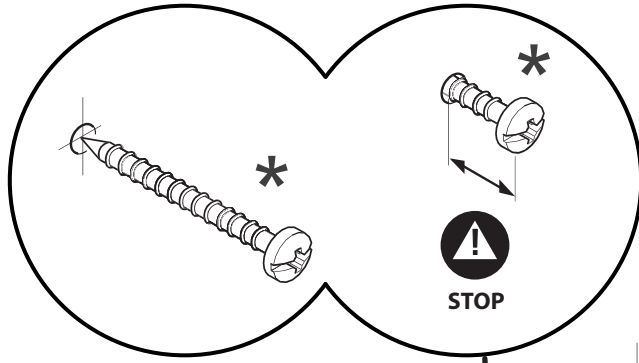
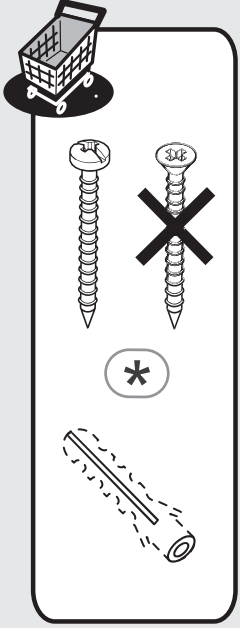

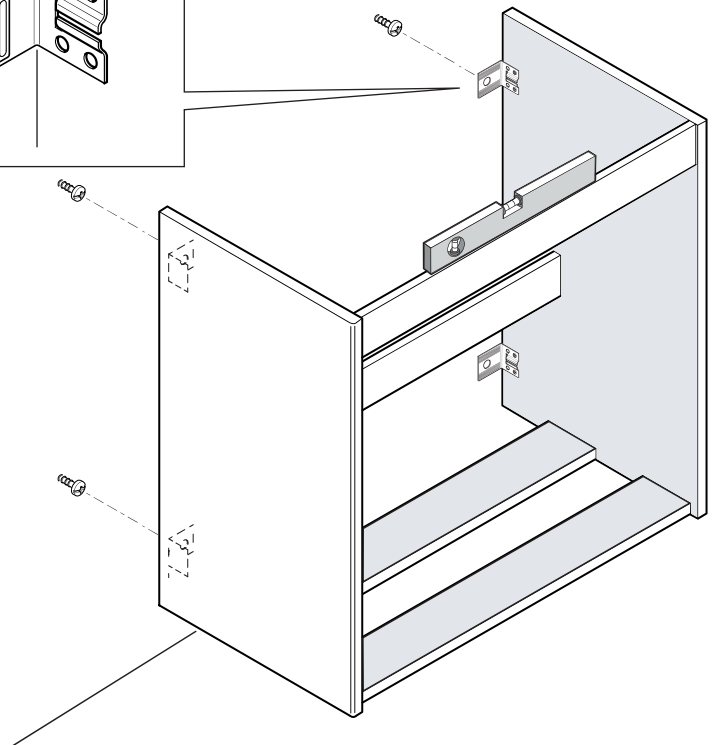
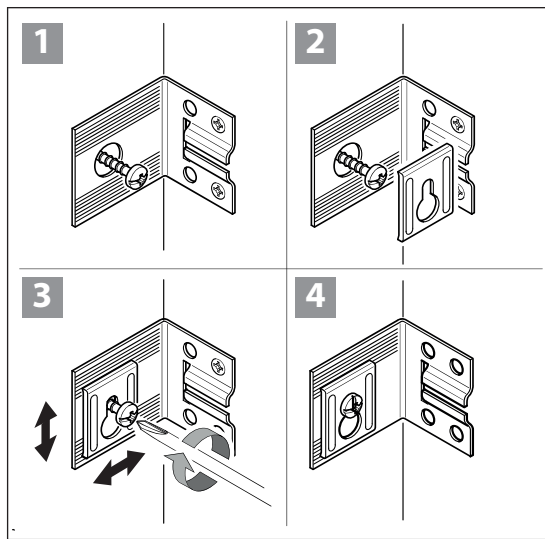
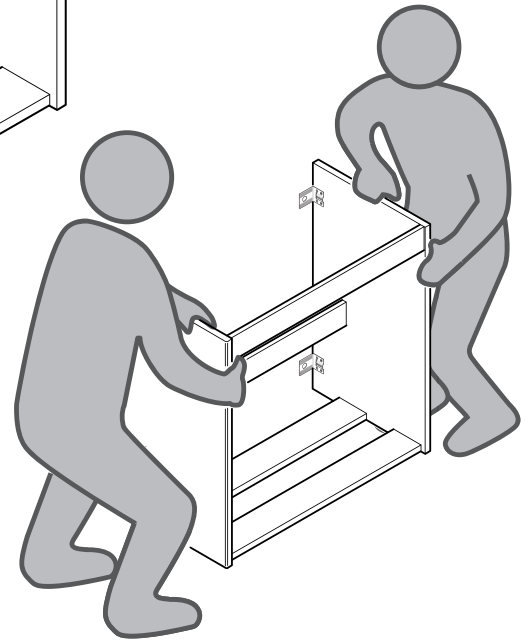
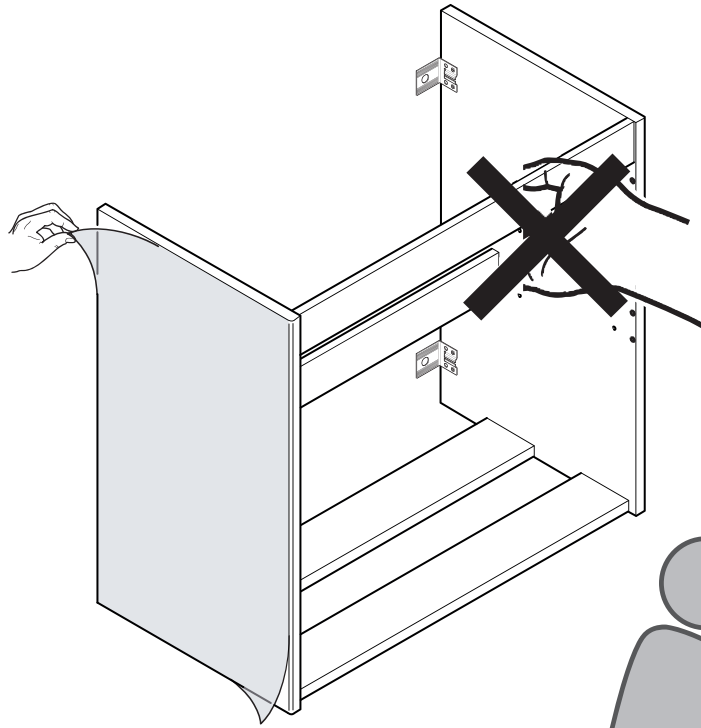
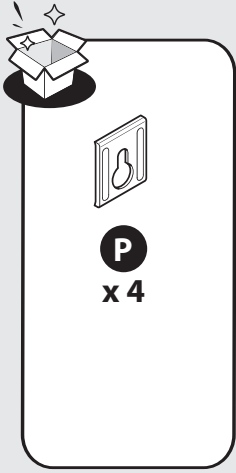

41

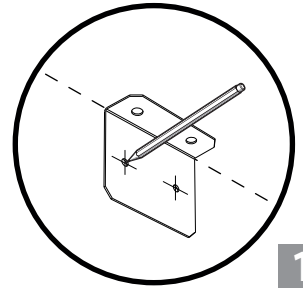
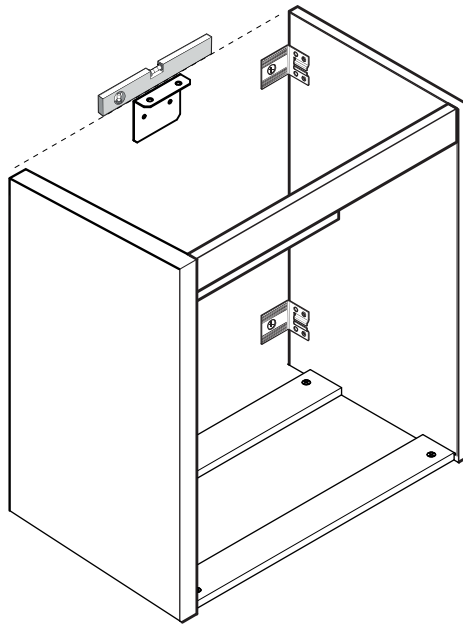
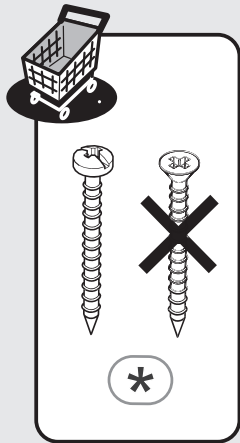
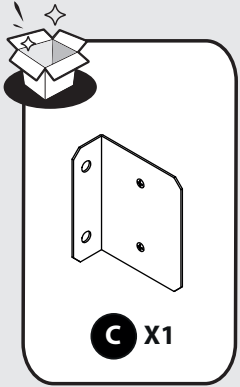

1

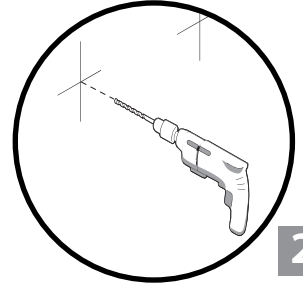

2

42

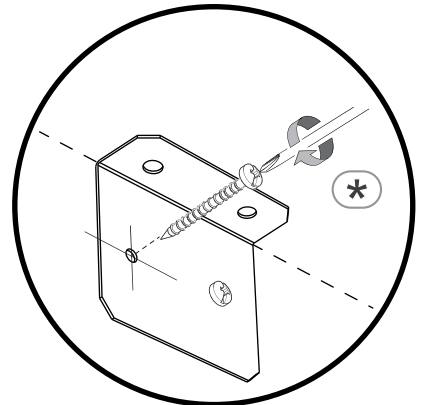
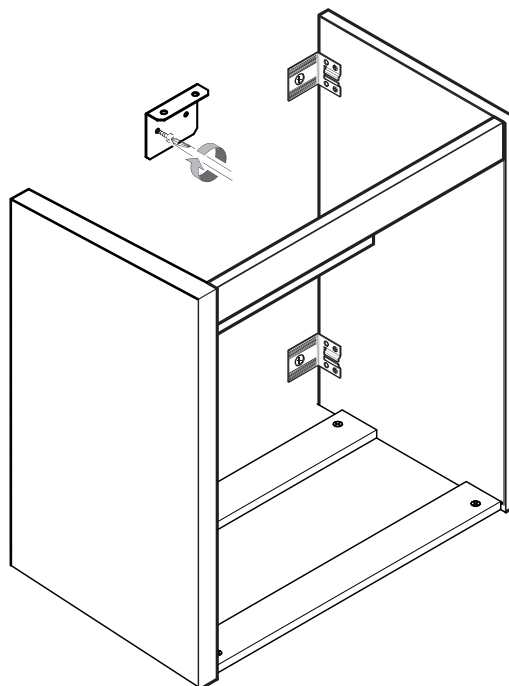

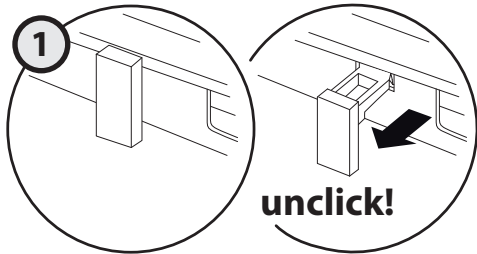
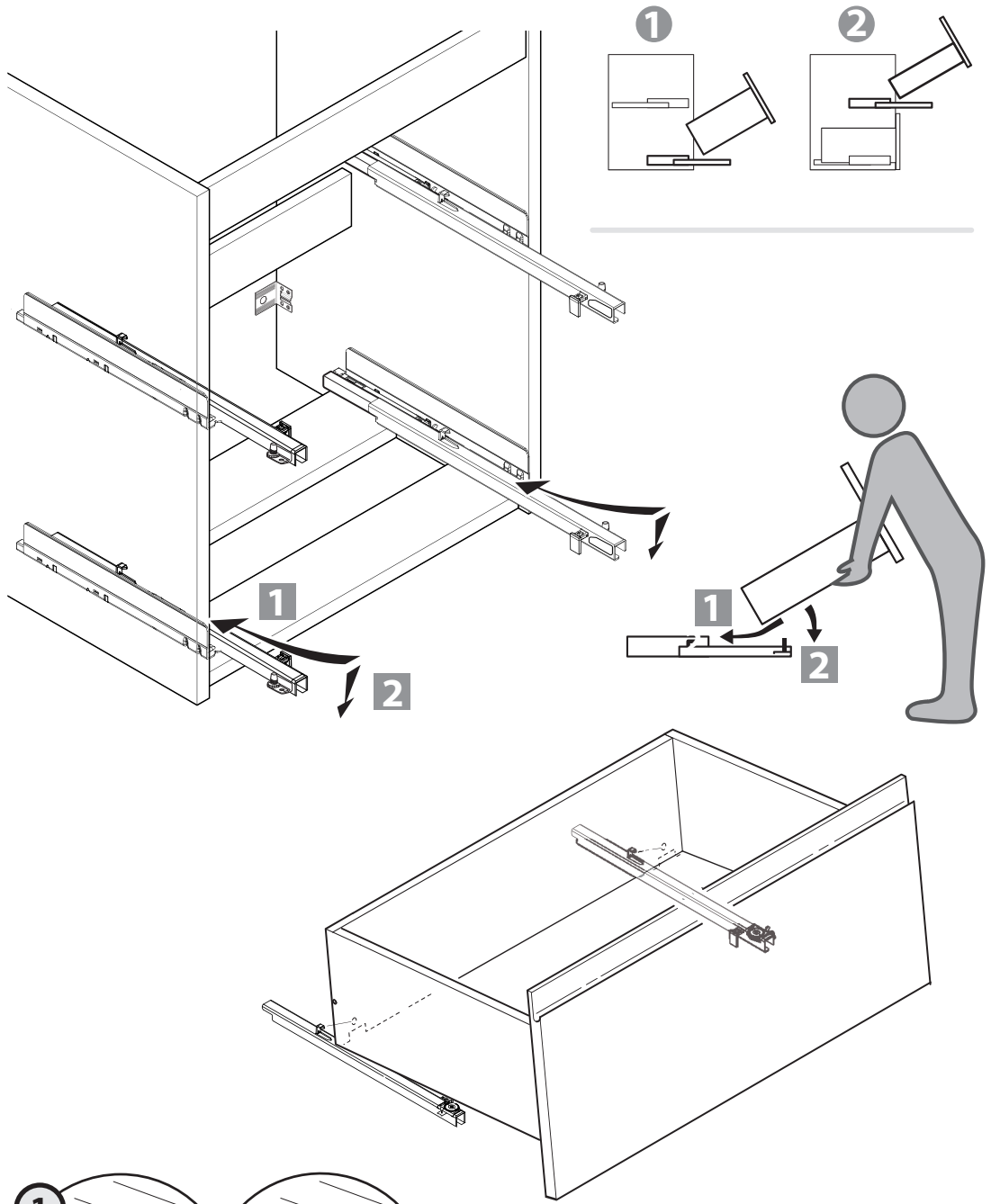

x2

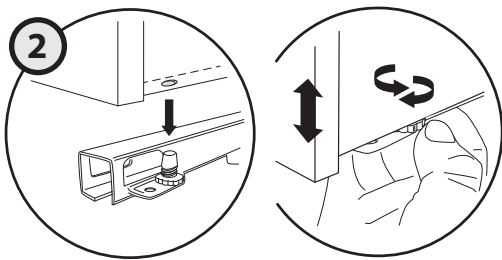

x2

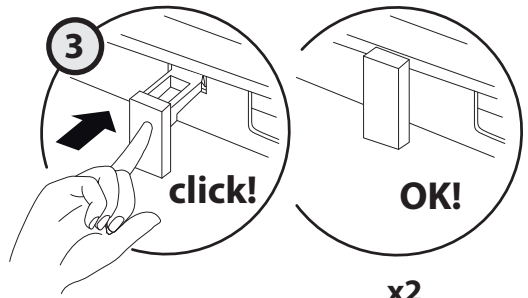

x2

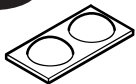

R X2

(Ø10x1,5)

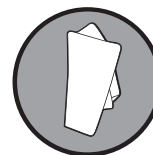
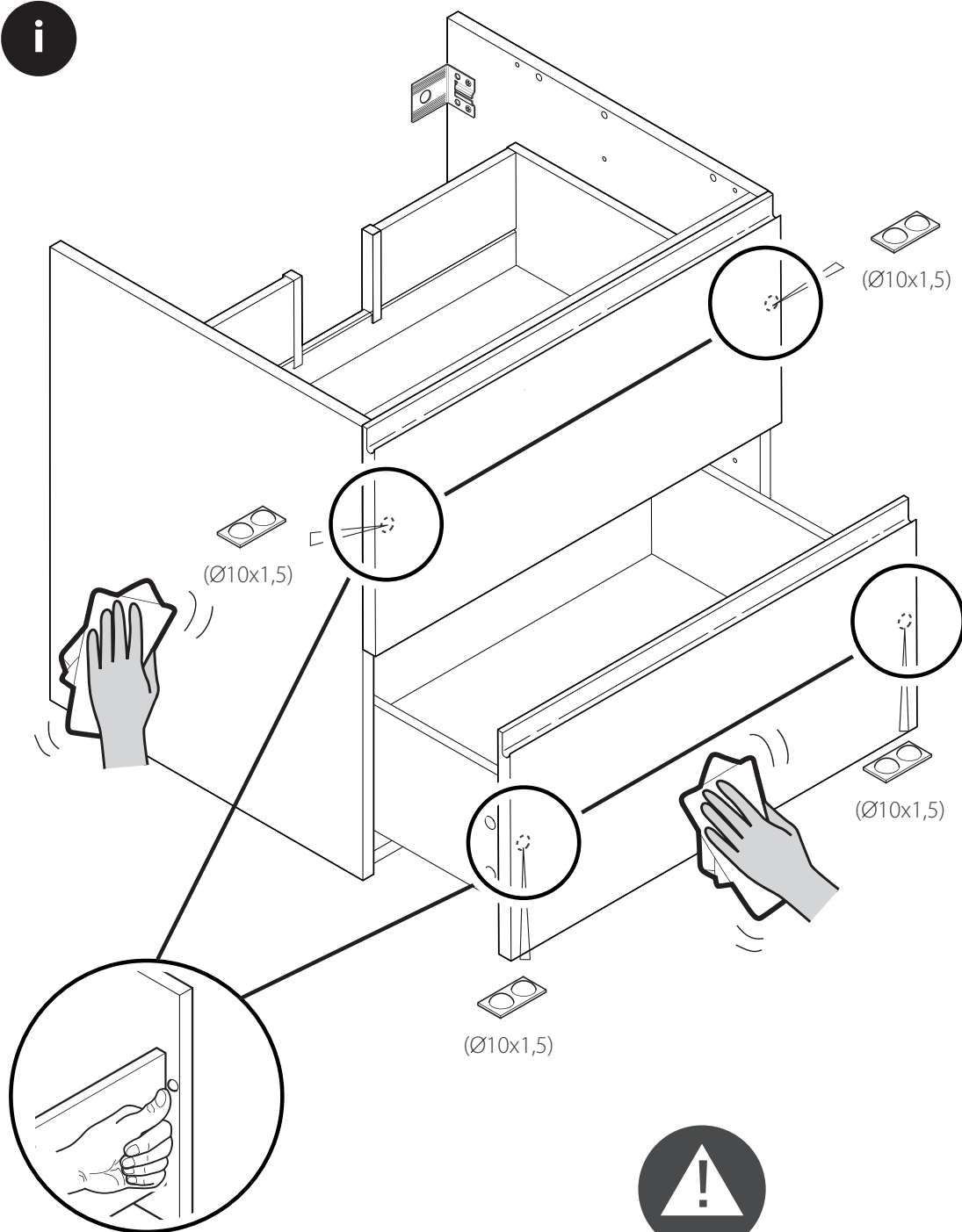



(A)x3

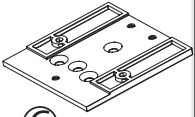

(C)

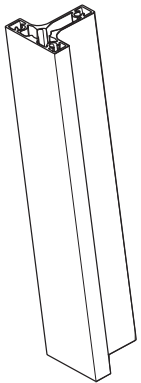

(D)



+

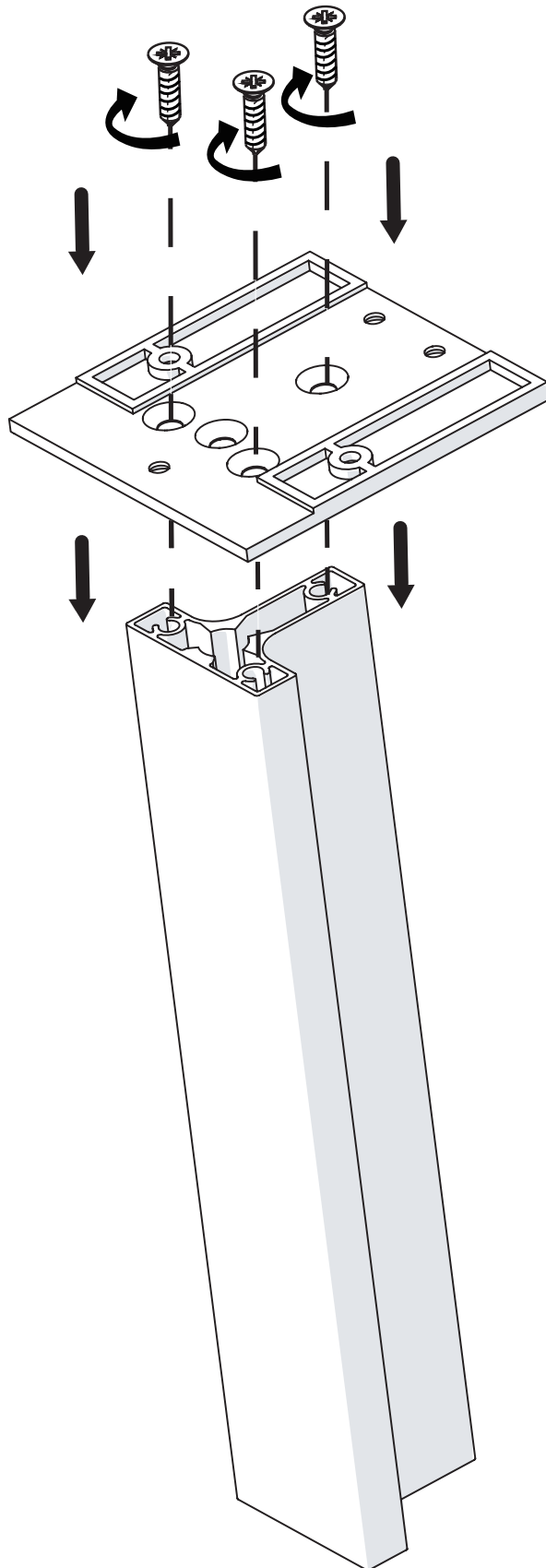

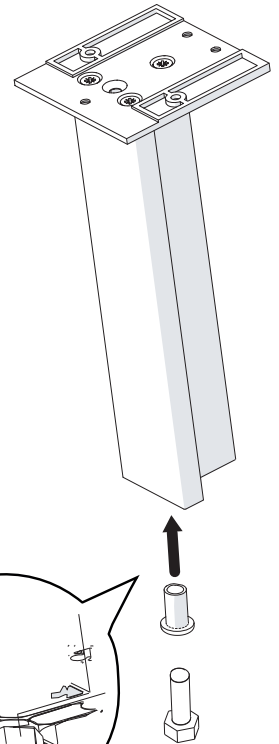
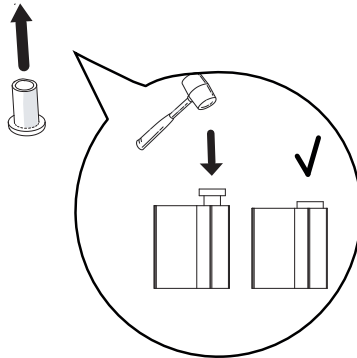
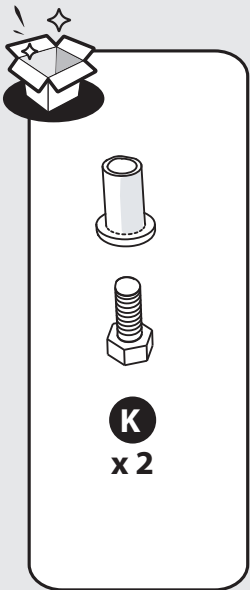
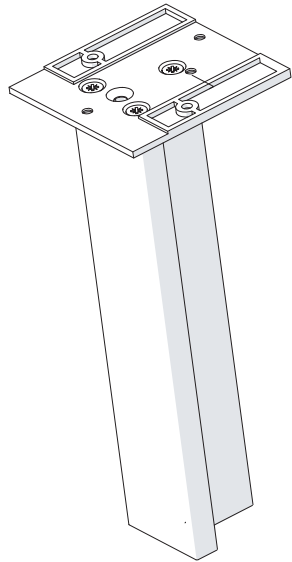
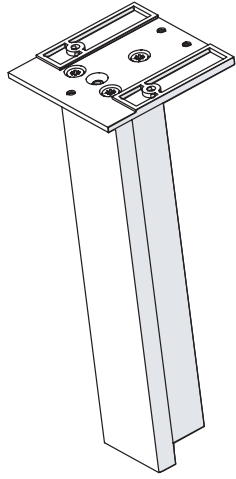
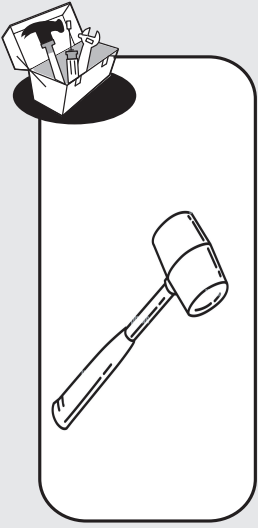

x2

46

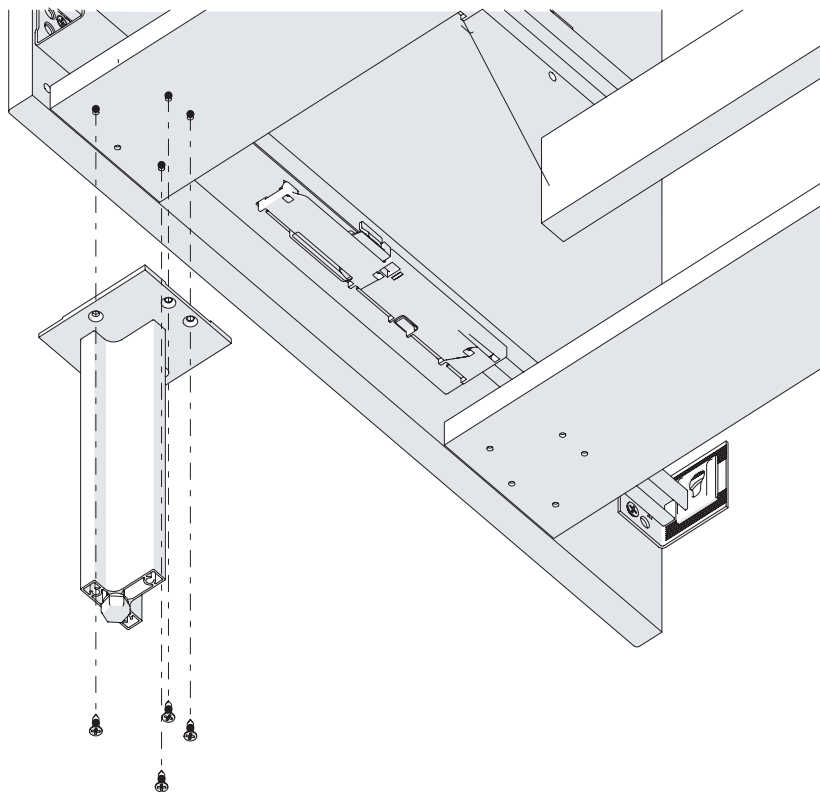
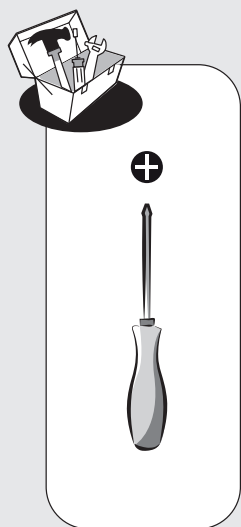

47

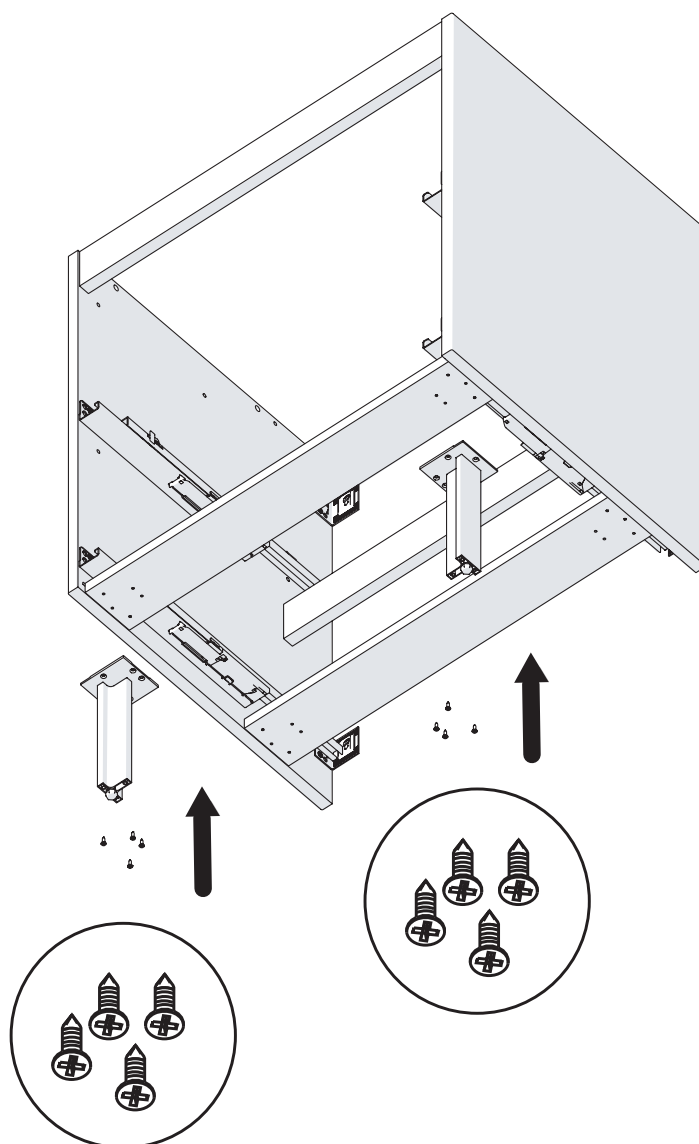
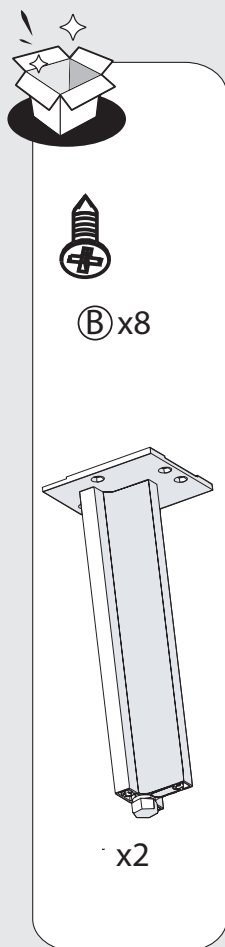

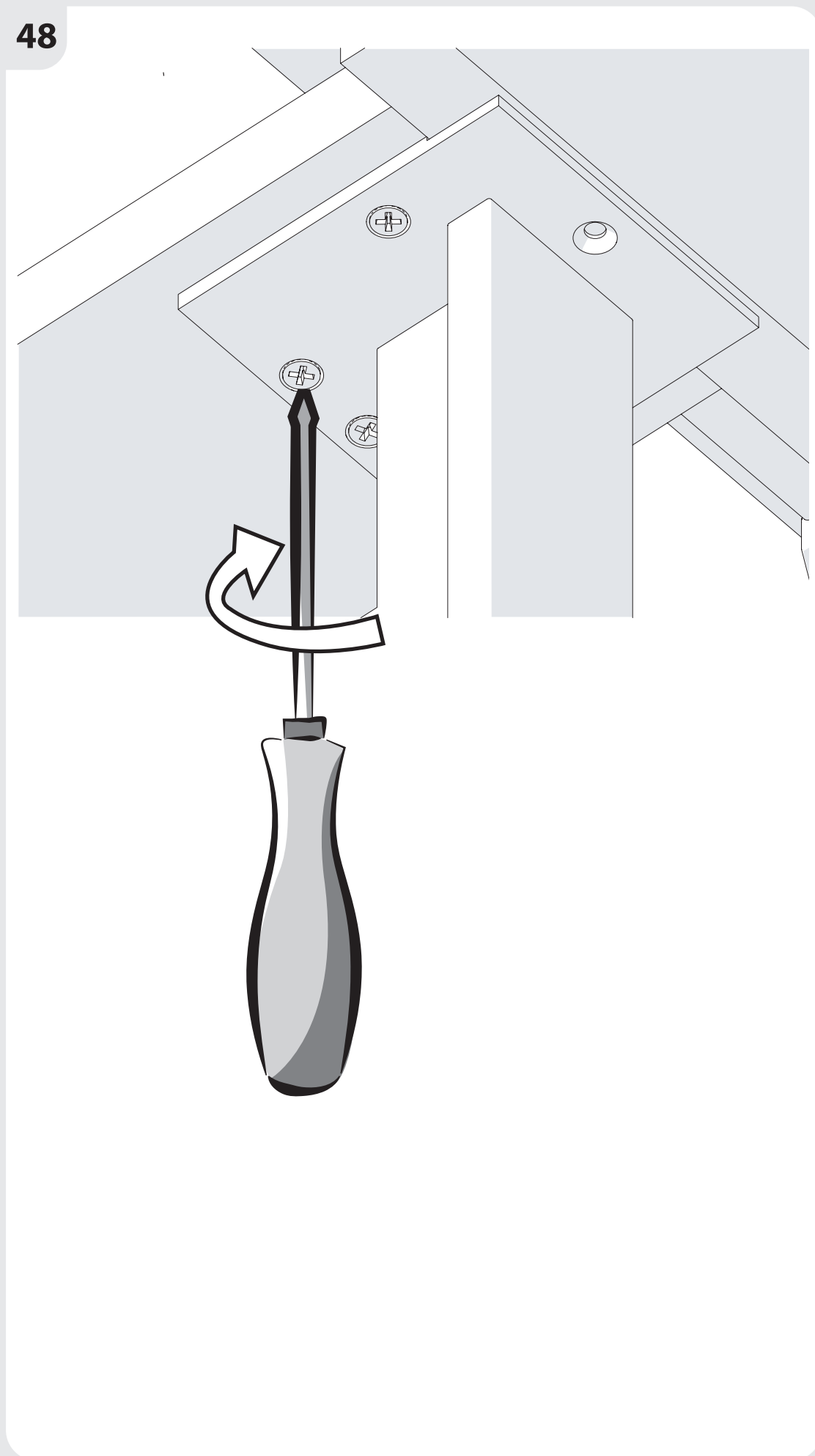
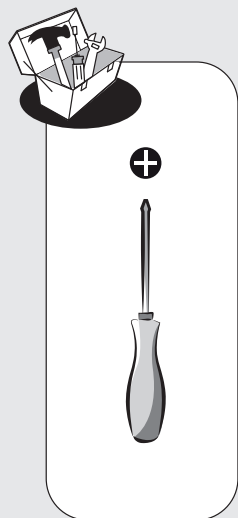

49

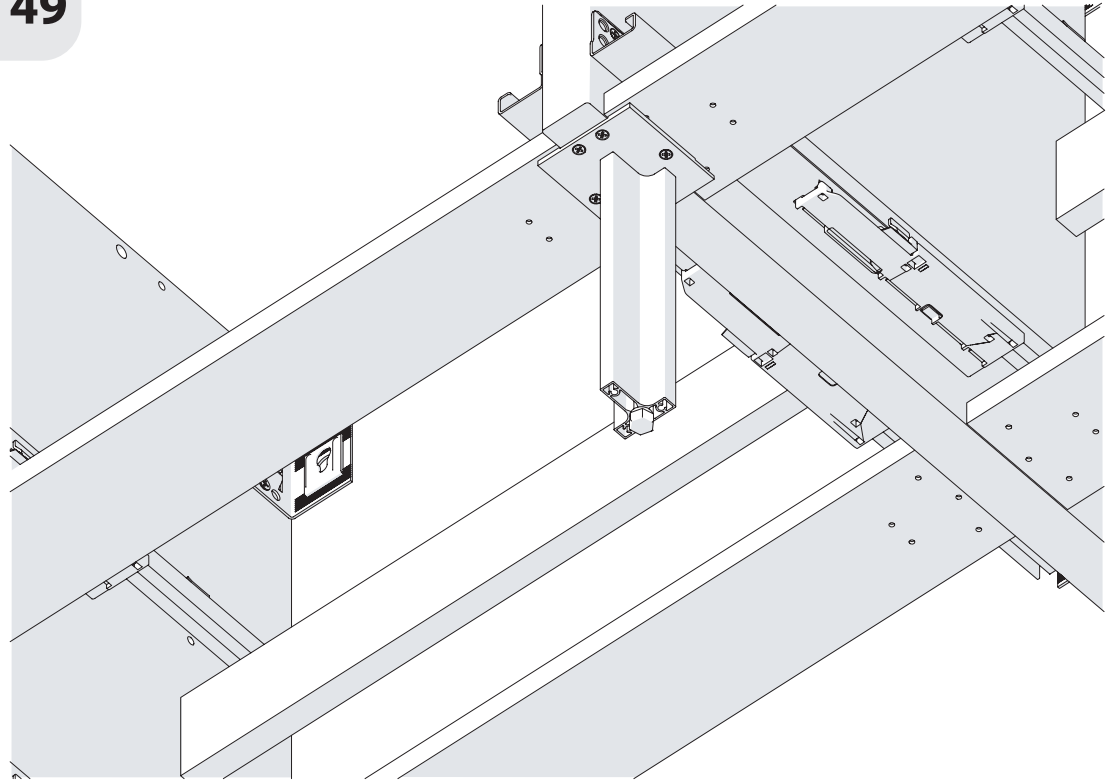
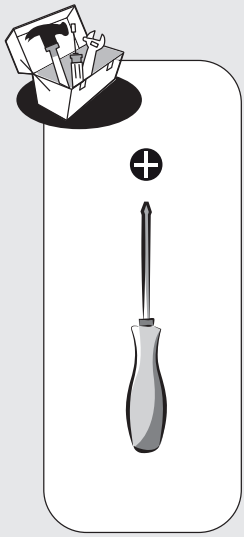

50

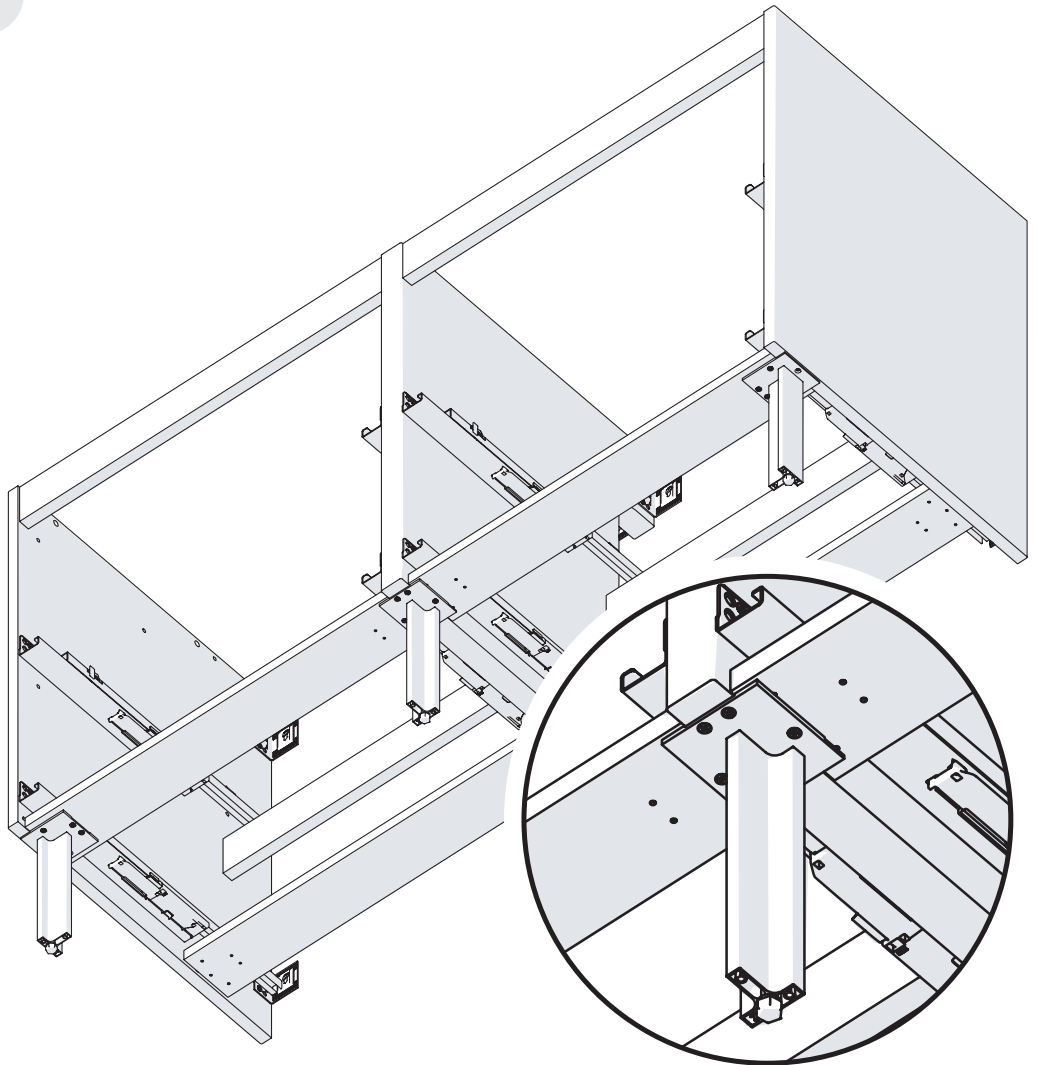

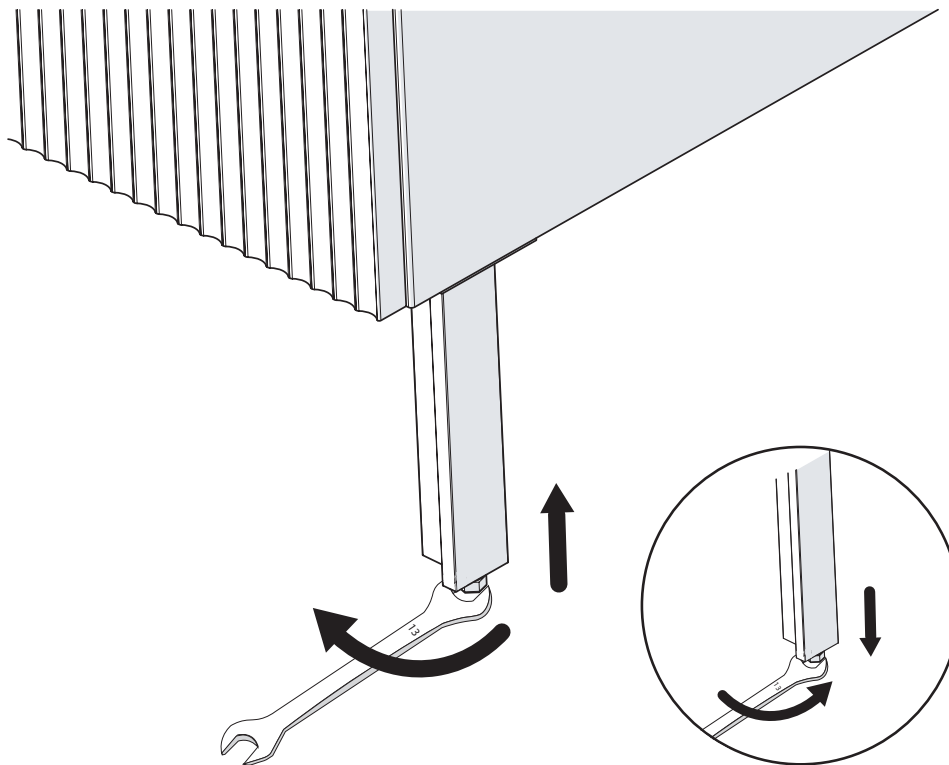
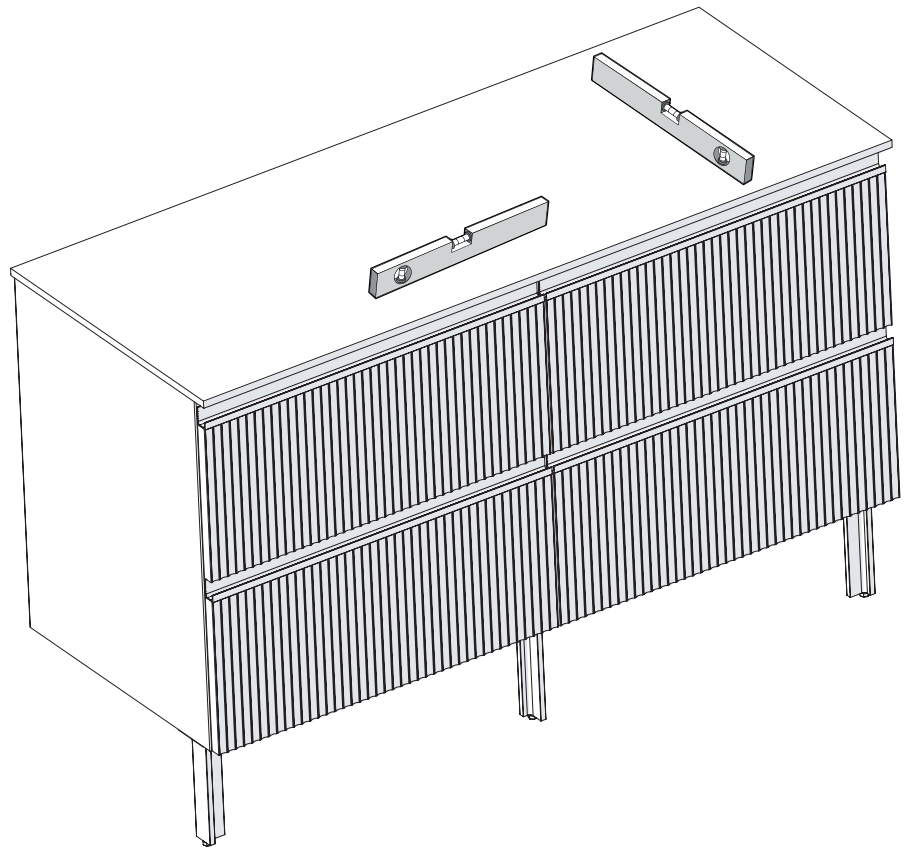
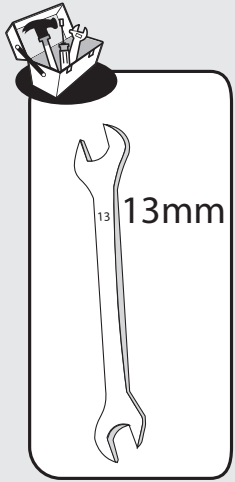

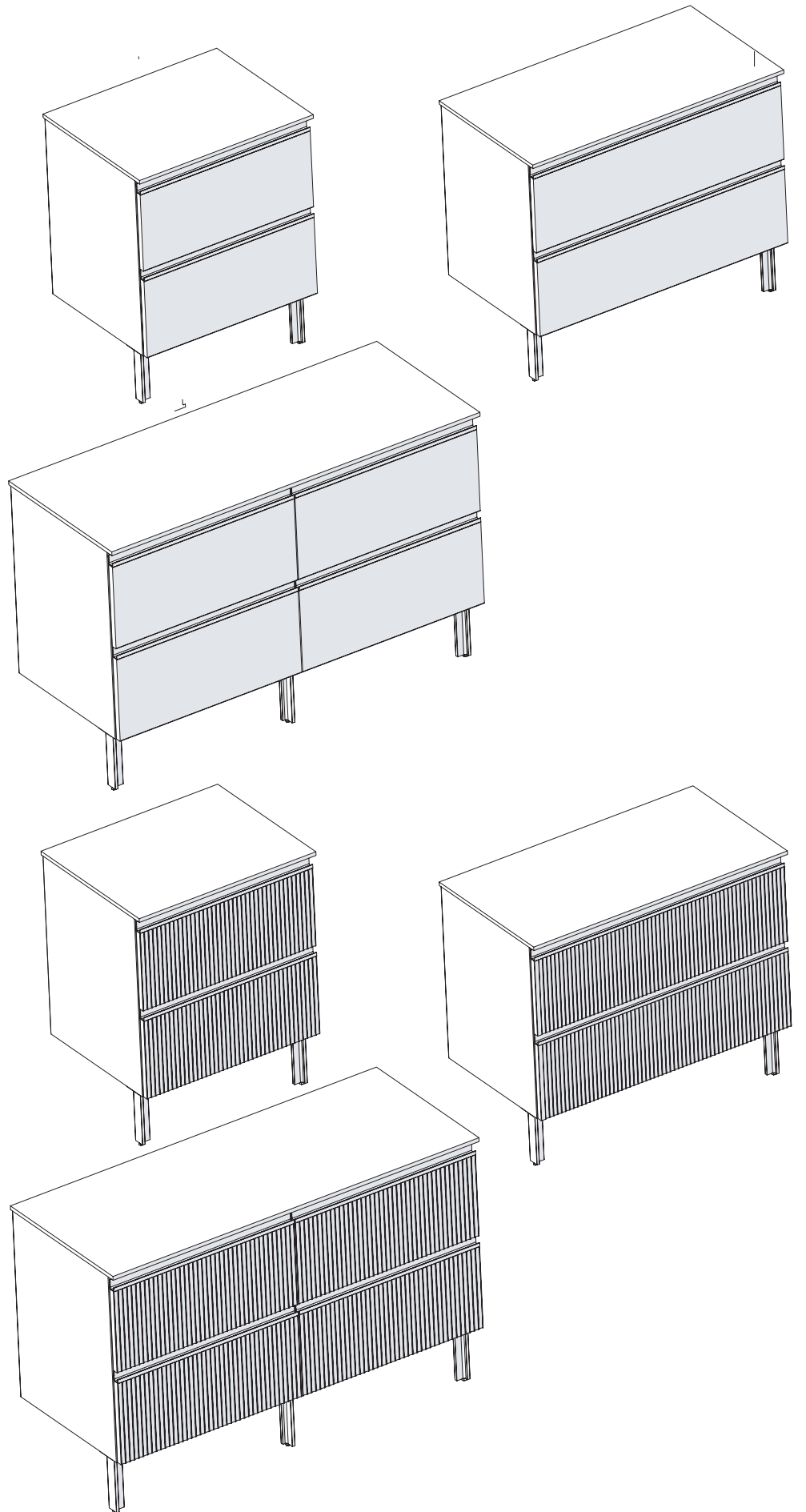



Ce meuble se recycle,
s'il n'est plus utilisable
déposez-le en déchèterie.
Notice à trie .
Pour en savoir plus :
www.quefairedemesdechets.fr

- ES** Si ya no puede utilizarse, este mueble se puede reciclar, deposítelo en la unidad de clasificación de residuos.
- PT** Este móvel é reciclável. Quando deixar de ser utilizado, deposite-o num centro de reciclagem de resíduos.
- IT** Questo mobile può essere riciclato, portatelo in un'isola ecologica se inutilizzabile.

- EL** Το έπιπλο αυτό είναι ανακυκλώσιμο, εάν δεν μπορεί πλέον να χρησιμοποιηθεί τοποθετήστε το σε χώρο αποβλήτων.
- PL** Mebel ten poddawany jest recyklingowi, kiedy przestaje być użyteczny należy go dostarczyć do punktu zbiórki odpadów.
- UA** Цей предмет меблів підлягає переробці. Якщо його більше не можна використовувати, віднесіть його до центру переробки відходів.
- RO** Acest mobilier s poate fi reciclat, dacă nu mai poate fi utilizat aruncați-l la groapă de gunoi.
- EN** This piece of furniture is recyclable. If it cannot be used anymore, please take it to the waste recycling centre.



* Garantie 10 ans / 10 años de garantía / Garantia de 10 anos / Garanzia 10 Anni /
Εγγύηση 10 ετών / Gwarancja 10-letnia / Гарантія 10 років / 10 ani garantie /
10-year guarantee

Made in Italy
Країна походження: Італія

ADEO Services - 135 Rue Sadit Carnot - CS 00001- Ronchin 59 790 - France

Виробник: ТОВ "Адео Сервісез С.А.", вул. Саді Карно, CS 00001, 59790 Роншен, Франція.
Імпортер: ТОВ "Леруа Мерлен Україна", 04201 Україна, м.Київ, вул. Полярна 17А,
+380 44 498 46 00. Імпортер приймає претензії від споживачів щодо товару,
а також проводить його ремонт, технічне і гарантійне обслуговування.

Imported by Adeo South Africa (PTY) LTD T/A Leroy Merlin,
Hosted in Leroy Merlin Fourways Store 35 Roos Street, Witkoppen Ext 97, Sandton, 2191 Johannesburg,
Gauteng, South Africa
Tel: +27 10 493 8000 Email: contact@leroymerlin.co.za

